

CombiTemp Temperature Measuring System

Flexible building block concept

All wetted parts in acid-proof, stainless steel

Pt100 or Pt1000 sensors, 2- or 4-wire

DIN A or B (1/1, 1/3, 1/6) elements

Sensor tubes

Cable sensors

Flush mounted surface sensor

ø80 mm stainless steel housing

DIN head, form B

Hygienic connections

Standard or fast response time

Display and 4...20 mA transmitter

(Standard and Ex versions)



Description

CombiTemp comprises a series of basic elements which can be combined to various temperature sensors and transmitters. The system includes 4-wire Pt100 cable sensors.

Being a building block system CombiTemp offers a great flexibility in respect to modification, service and maintenance.

A wide range of process connections according to national and international standards, sensor elements and transmitters, can be selected to meet the actual requirements.

The parts can be assembled by the user or delivered assembled and calibrated, if relevant.

Provided an 80 mm dia. housing is used, options are also a 4...20 mA configurable display or, for stand alone indicating purposes, a battery powered display.

CombiTemp is particularly suitable for use in food, beverage, pharmaceutical and chemical industries.

A complete temperature sensor can be ordered on one type number. Please refer to CombiTemp Accessories data sheet for a comprehensive range of accessories.

Please refer to the separate data sheets for information and ordering details for transmitters and displays.

**BOURDON
HAENNI**

made to measure

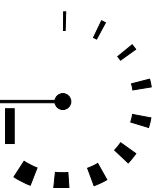

Technical Data

Environmental conditions

Media temperature, std.	-50...400°C
Surface sensor	-40...150°C
Ambient temperature (or max. temperature range for display/transmitter)	-40...160°C
Humidity (or max. humidity for display/transmitter)	< 100% RH, condensing
Protection class	DIN housing IP 65 ø80 mm housing IP 65 + IP 66
Vibrations	GL, test 2 (sensor tubes < 200 mm only)

Disposal of product and packing

According to national laws or by returning to Bourdon-Haenni

Sensor tube and connection

Material	Acid-proof, stainless steel (AISI 316L/W.1.4404)
Media pressure	Max. 16 bar
Time constant $t_{0.5}$	See table below
Mechanical tolerances	ISO 2768-m

Sensor element

Sensor type	Pt100, Class A or B Pt1000, Class B
Accuracy	DIN/EN/IEC 60751
1/1 DIN B:	$\pm(0.3 + 0.005 \times t) \text{ } ^\circ\text{C}$
1/3 DIN B:	$\pm 1/3 \times (0.3 + 0.005 \times t) \text{ } ^\circ\text{C}$
1/6 DIN B:	$\pm 1/6 \times (0.3 + 0.005 \times t) \text{ } ^\circ\text{C}$
1/1 DIN A:	$\pm(0.15 + 0.002 \times t) \text{ } ^\circ\text{C}$

Time Constant $\tau_{0.5}$

Sensor type		Liquids		Air	
Dimension	Response	Insert	0.4 m/sec.	3 m/sec.	0 m/sec.
ø6 mm tube	fast		< 1.5 sec.	< 21.4 sec.	< 135.6 sec.
ø8 mm tube	fast		< 1.5 sec.	< 33.6 sec.	< 181.0 sec.
ø10 mm tube	fast		< 1.5 sec.	< 46.8 sec.	< 238.9 sec.
ø12 mm tube	fast		< 1.5 sec.	< 59.9 sec.	< 311.4 sec.
ø6 mm tube	normal		< 6.1 sec.	< 27.2 sec.	< 137.8 sec.
ø8 mm tube	normal		< 7.6 sec.	< 47.7 sec.	< 200.9 sec.
ø10 mm tube	normal		< 11.1 sec.	< 57.8 sec.	< 270.6 sec.
ø12 mm tube	normal		< 16.2 sec.	< 70.8 sec.	< 319.8 sec.
ø8 mm tube	normal	5.6 mm	< 13.6 sec.	< 51.1 sec.	< 253.1 sec.
ø10 mm tube	normal	5.6 mm	< 28.1 sec.	< 67.0 sec.	< 271.1 sec.
ø12 mm tube	normal	5.6 mm	< 31.3 sec.	< 82.3 sec.	< 289.3 sec.
Surface sensor, flush mounted			< 1.0 sec.		

Dimensional Drawings - Mounting Details

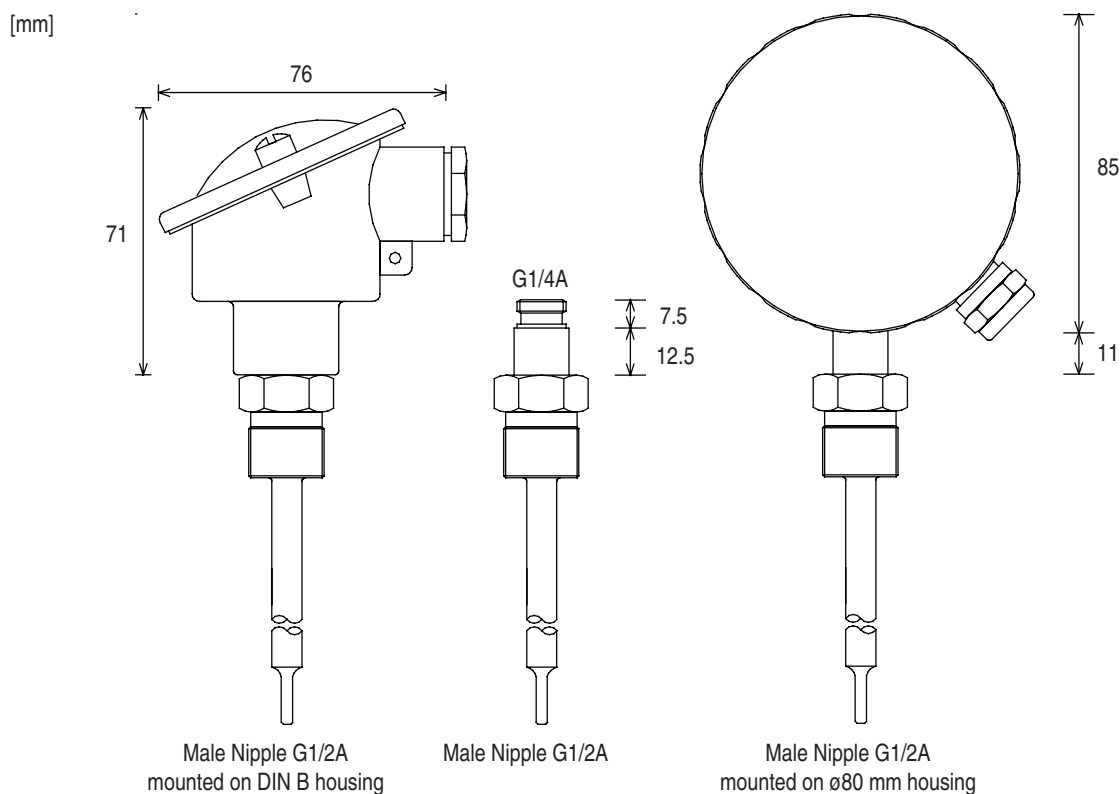

Examples of Application

[mm]

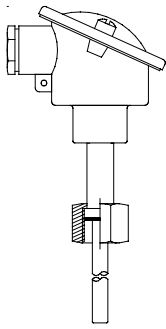

8141 4211 0500 110 xxxx

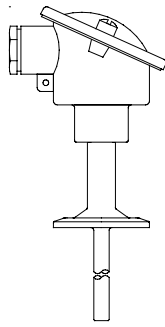

8141 H241 0500 110 xxxx

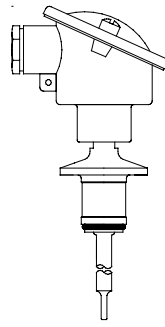

8142 D232 0500 110 xxxx

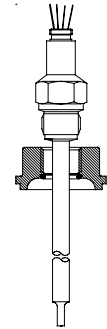

8142 C252 0000 000 xxxx
+CombiConnect connection

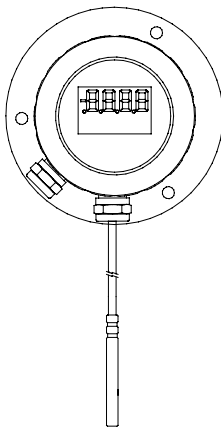

8140 0007 03B2 210 xxxx
Cable sensor 81 41-231
Display 81 46-525
Transmitter 81 47-525

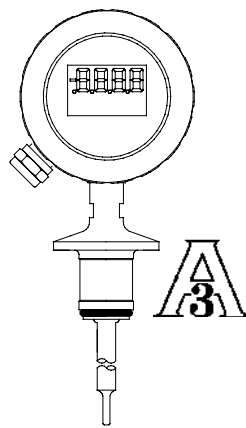

8142 D231 02A2 213 xxxx
Display 81 46-525
Transmitter 81 47-525

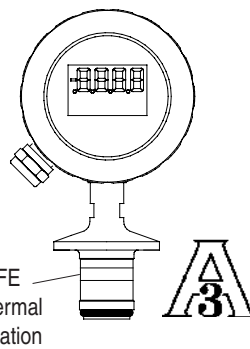

8140 E010 02A2 213 0000
Display 81 46-525
Transmitter 81 47-525

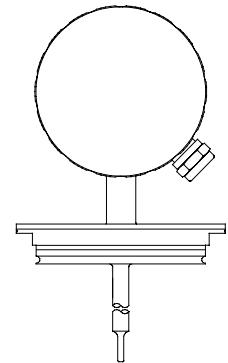

8142 G152 02A1 210 xxxx
Transmitter 81 47-525

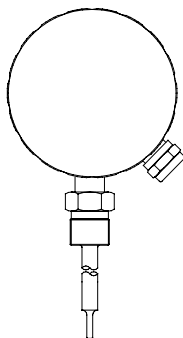

8142 3212 02A1 110 xxxx

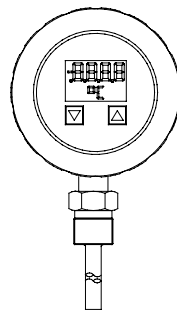

8141 3211 0272 010 xxxx
BattTemp 86 30-511

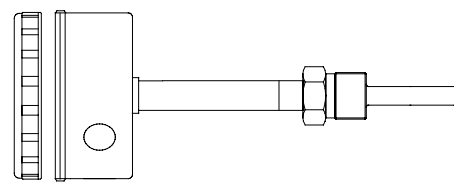

8141 3212 12A2 121 xxxx

Ordering Details - CombiTemp Series

	814x	xxxx	-----
Sensor tip			
	4´ digit		
Not specified		0	
Normal response sensor tip		1	
Fast response sensor tip, Note {1}, {6}		2	
Connection			
	5´ digit		
Not specified		0	
Sensor tube without thread or connection		1	
R1/2 Male nipple, ISO 7/1		2	
G1/2A Male nipple, ISO 228/1		3	
G1/2 Rotating female nut, ISO 228/1		4	
G1/2A Rotating male nipple, ISO 228/1		5	
G3/4 Rotating female nut, ISO 228/1		6	
G3/4A Rotating male nipple, ISO 228/1		7	
G1 Rotating female nut, ISO 228/1		8	
G1A Rotating male nipple, ISO 228/1		9	
1/2" - 14 NPT Male nipple, ANSI/ASME B1.20.1		A	
G1/2A Male nipple for CombiConnect, ISO 228/1		C	
3A/DN38 Hygienic, sensor tube, 3A approved		D	
3A/DN38 Hygienic, flush mounted surface sensor, 3A approved		E	
GEA Tuchenhausen Varivent flange, DN40/DN50		G	
Clamp DN25/38, ISO 2852, 3A approved		H	
Clamp DN51, ISO 2852, 3A approved		I	
1/2" - 3/4" Tri-clamp®		K	
M20 x 1.5 Male nipple, DS/ISO 261		M	
SMS 1145 Rotating female nut, DN38		P	
SMS 1145 Rotating female nut, DN51		Q	
As customer specification		S	
Sensor tube dimension			
	6´ digit		
Not specified		0	
ø6 mm x 1 mm, AISI 316L, max. length 600 mm, Note {6}		1	
ø8 mm x 1 mm, AISI 316L, max. length 6000 mm, Note {2}		2	
ø10 mm x 1 mm, AISI 316L, max. length 6000 mm		3	
ø12 mm x 1 mm, AISI 316L, max. length 6000 mm		4	
As customer specification		S	
Sensor element			
	7´ digit		
Not specified or empty sensor tube		0	
Pt100, 1/1 DIN B, single, specified accuracy -50...400°C		1	
Pt100, 1/1 DIN B, double, specified accuracy -50...400°C		2	
Pt100, 1/3 DIN B, single, specified accuracy 0...150°C		3	
Pt100, 1/3 DIN B, double, specified accuracy 0...150°C		4	
Pt100, 1/6 DIN B, single, specified accuracy 0...100°C		5	
Pt100, 1/6 DIN B, double, specified accuracy 0...100°C		6	
Pt100, 1/1 DIN A, single, specified accuracy -50...400°C		7	
Pt100, 1/1 DIN A, double, specified accuracy -50...400°C		8	
Pt100, 1/1 DIN B, single, specified accuracy -50...600°C, Note {7}		9	
Pt1000, 1/3 DIN B, single, specified accuracy -50...400°C		A	
Pt1000, 1/1 DIN B, single, specified accuracy -50...400°C		B	
As customer specification		S	
Sensor insert type			
	8´ digit		
Not specified		0	
Sensor tube with embedded sensor element, 2-wire		1	
Sensor tube with embedded sensor element, 4-wire		2	
ø5.6 x 0.5 mm insert AISI 316, 2-wire, max. length 600 mm, Note {3}, {7}		3	
ø5.6 x 0.5 mm insert AISI 316, 4-wire, max. length 600 mm, Note {3}, {7}		4	
ø5.6 x 0.5 mm insert spring-loaded AISI 316, 2-wire, max. length 600 mm, Note {3}, {7}		5	
ø5.6 x 0.5 mm insert spring-loaded AISI 316, 4-wire, max. length 600 mm, Note {3}, {7}		6	
Cable sensor, 4-wire, Note {4}		7	

Ordering Details - CombiTemp Series (continued)

	----- XXXX XXX XXXX				
Cooling neck	9' digit				
Not specified		0			
1 off cooling neck (71 mm)		1			
2 off cooling neck (142 mm)		2			
3 off cooling neck (213 mm)		3			
As customer specification		S			
Housing	10' digit				
Not specified		0			
ø80 mm stainless steel housing, Note {5}		2			
ø80 mm stainless steel housing with ø110 mm wall bracket, Note {5}		3			
DIN B head with cover and M20 gland		5			
DIN B head with cover and M20 gland, shield connection terminal		6			
As customer specification		S			
Electrical connection	11' digit				
Not specified or std. DIN B head selected in the previous choice		0			
ø80 mm housing: 1 off M20 x 1.5 adaptor and 1 off blind plug (no gland incl.)		5			
ø80 mm housing: 2 off M20 x 1.5 adaptor (no gland incl.)		6			
ø80 mm housing: 2 off blind plugs		7			
ø80 mm housing: 1 off M16 gland and 1 off blind plug		A			
ø80 mm housing: 2 off M16 gland		B			
ø80 mm housing: 1 off M16 with shield connection terminal and 1 off blind plug		C			
DIN B head: 1 off M20 gland for marine applications		D			
As customer specification		S			
Cover or display	12' digit				
Not specified		0			
Cover for ø80 mm housing		1			
Display, Note {4}		2			
Terminal block or transmitter	13' digit				
Not specified		0			
Ceramic terminal block		1			
Transmitter, Note {4}		2			
Assembling	14' digit				
Not specified		0			
Assembled, process connection at the base		1			
Assembled, process connection at the rear (ø80 mm housing only)		2			
Welded, process connection at the base (ø80 mm housing only)		3			
Welded, process connection at the rear (ø80 mm housing only)		4			
Certificates	15' digit				
Not specified		0			
Material 3.1.b (EN 10204)		1			
Calibration certificate		2			
Material 3.1.b (EN 10204) and calibration certificate		3			
Sensor tube length (L)	16...19' digit				
Length in mm. Please observe max. lengths					XXXX

Notes:

- {1} Single sensor element only. Max. sensor length 300 mm.
- {2} Max. 1000 mm with cable sensor.
- {3} ø80 mm housing: Insert only if sensor tube is mounted at the rear. Observe length, refer to „Sensor Insert Type“.
- {4} Refer to data sheet. Specify separate type number and configuration.
- {5} Assembling is mandatory. Valid for 3A applications.
- {6} Embedded sensors only.
- {7} Not valid for a sensor with fast response tip.

Dimensional Drawings

[mm]

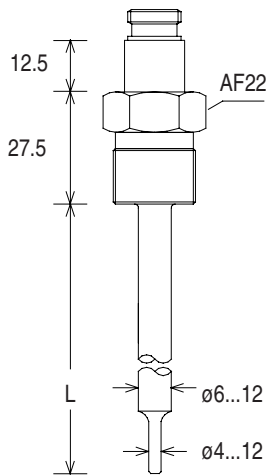

Male nipple G1/2A, R1/2 and M20 x 1.5

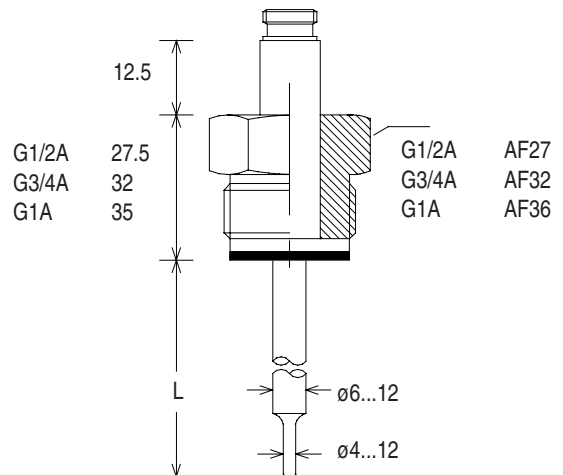

Rotating male nipple G1/2A, G3/4A and G1A

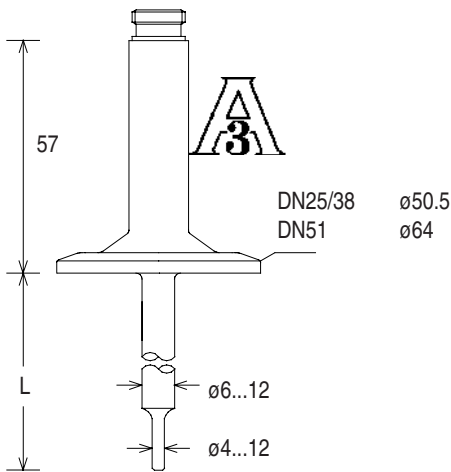

Clamp DN25/38/51
EPDM gasket included

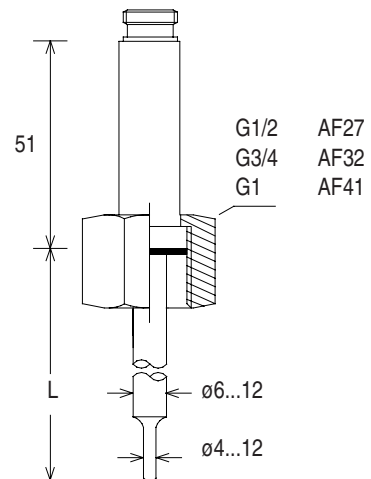

Rotating female nut G1/2, G3/4 and G1

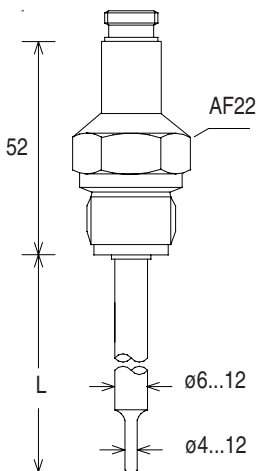

Male nipple G1/2A for CombiConnect

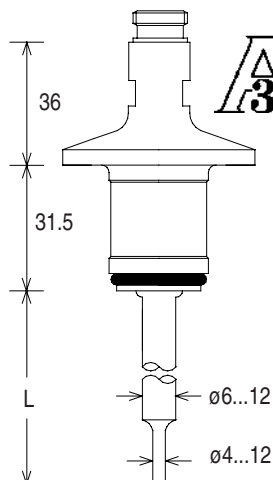

3A/DN38 sensor tube
EPDM gasket included

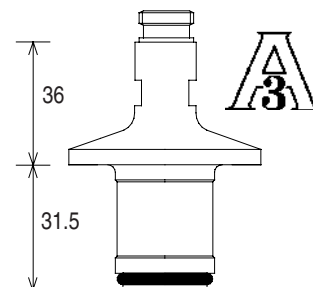

3A/DN38 flush mounted
surface sensor
EPDM gasket included

Dimensional Drawings

[mm]

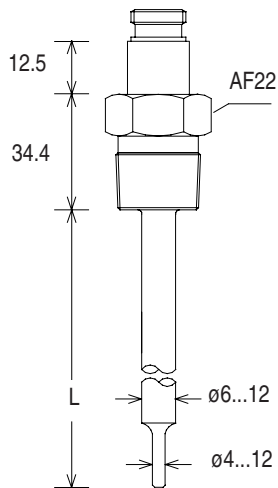

Male nipple 1/2" - 14 NPT

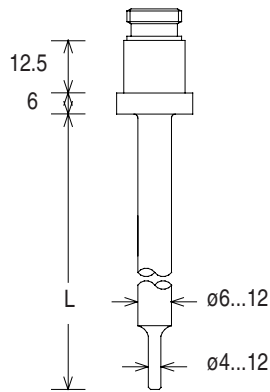

Sensor tube without connection

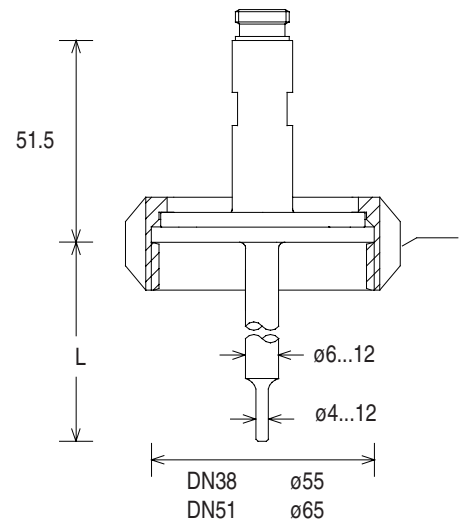

SMS 1145 rotating female nut

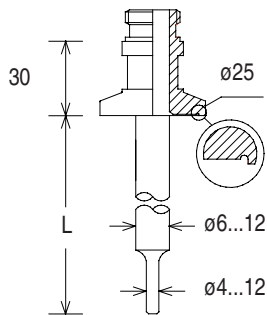

Tri-Clamp® 1/2 - 3/4

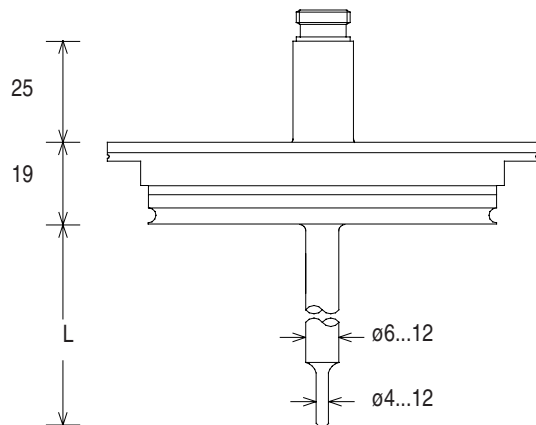

GEA Tuchenhagen Varivent DN40/DN50

Sensor inserts

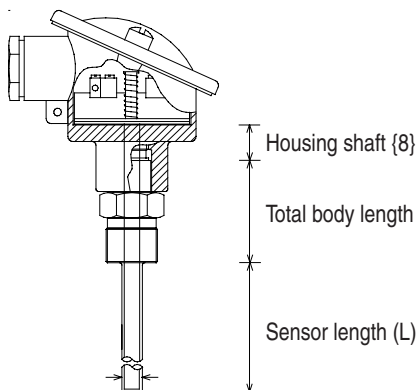

DIN housing with G1/2A male nipple connection and sensor insert

Note {8}

Housing shaft DIN housing: 11.5 mm
ø80 housing: 6.5 mm

Calculation of insert length:

When ordering an insert the length must be calculated from the formula:

Insert length = Sensor length + total body length + housing shaft
(Total body length can be calculated from the dimensional drawings on pages 6 and 7)

Example.

Insert for a G1/2A male nipple sensor in a DIN housing, 100 mm sensor tube, normal response sensor tip:

Housing shaft = 11.5 mm
Total body length = 27.5 + 12.5 = 40 mm (see page 6)
Sensor length = 100 mm

This insert must be ordered with a 151.5 mm sensor tube.

4-wire Sensors

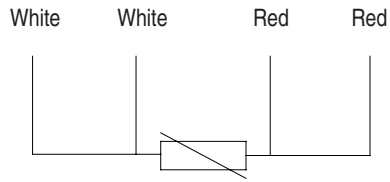

Warning:
One of the wires may not be connected in case of a 3-wire connection to the temperature transmitter

Double Elements

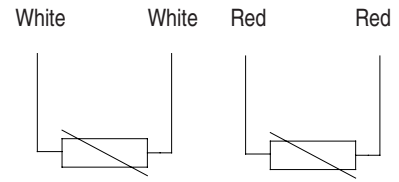

Application Photos



ø80 mm housing with FlexView
Gland (blind plug at the rear)
Clamp connection
Fast response sensor



Cut through DIN - B housing
FlexTop 2201 temperature transmitter
G1/2A male nipple connection
Normal response sensor



ø80 mm housing with 2 glands
Cover not mounted
3A connection at the rear
Fast response sensor

UK/2004-10-02 This data sheet may only be reproduced in full.