



100 Series

100 Series

PRESSURE, VACUUM, DIFFERENTIAL PRESSURE AND TEMPERATURE SWITCHES



FEATURES

- Single Switch Output
- Proof Pressures to 7,000 (482,6 bar) diaphragm or 10,000 psi (689,5 bar) piston
- Adjustable Ranges:
 - Pressure:
30 "Hg Vac to 5000 psi (-1 to 344,7 bar)
 - "wc Ranges:
300 "wc Vacuum to 250" wc Pressure (-746,7 to 622,3 mbar)
 - Differential Pressure:
0.2 "wcd to 500 psid (0,5 mbar to 34,5 bar)
 - Temperature:
-180 to 650 °F (-117.8 to 343.3 °C)
- NEMA 4X Cast Aluminum Enclosure with Epoxy Coating
- Tamper-Resistant Set Point "lock"
- Heat Trace and Freeze Protection Thermostats

OVERVIEW

The 100 Series is a cost-effective pressure and temperature control for process plants and OEM equipment. The rugged, one piece enclosure features a slanted cover for wiring accessibility.

A wide variety of electrical and process-connection options make this series ideal for many applications, where weather-proof, ruggedness and versatility are required.

Various applications utilize the 100 Series: heat tracing, freeze protection, processing equipment (pumps, compressors), inputs for annunciator panels and fire suppression systems.



FEATURES

- UL listed, CSA certified and CE compliance to low voltage directive and pressure equipment directive
- Single switch (SPDT or DPDT) output
- Welded stainless steel diaphragm models
- Ultra low pressure, "wc models
- Optional sensor material for corrosive media
- Polished stainless steel sanitary connection

SPECIFICATIONS

STORAGE TEMPERATURE	-65° to 160°F (-54 to 71°C)
AMBIENT TEMPERATURE LIMITS	-40° to 160°F (-40 to 71°C); models 520-548, 700-706: 0 to 160°F (-18 to 71°C); Set point typically shifts less than 1% of range for a 50°F (28°C) ambient temperature change
SET POINT REPEATABILITY	Temperature models: ± 1% of adjustable range Pressure models 171-174, 218, 270-376, 520-535, 540-543, 700-706, 560-564: ± 1% of adjustable range; models 190-194, 183-189, 483-494, 544-548, 565-567, 610-680: ±1.5% of adjustable range Internal set point lock on all pressure models
SHOCK	Set point repeats after 15 G, 10 millisecond duration
VIBRATION	Set point repeats after 2.5 G, 5-500 Hz
ENCLOSURE	Die cast aluminum, epoxy powder coated, gasketed, captive cover screws
ENCLOSURE CLASSIFICATION	Designed to meet NEMA 4X requirements
SWITCH OUTPUT	One SPDT snap action switch; switch may be wired "normally open" or "normally closed"
ELECTRICAL RATING	15 A 125/250/480 VAC resistive
WEIGHT	2-7 lbs; Varies with model
ELECTRICAL CONNECTION	1/2" NPT (female); Two 7/8" diameter knockouts
PRESSURE CONNECTION	Models 218, 270-376, 610-680, 701-706: 1/4" NPT (female); Models: 171-194, 483-494, 520-535: 1/2" NPT (female); Models 540-548: 1/8" NPT (female); Models 560-564: 2" Sanitary Fitting; Models 565-567: 1.5" Sanitary Fitting (Sanitary fittings mate with Tri-Clamp® fitting systems)
TEMPERATURE ASSEMBLY	Bulb and capillary: 6 feet 304 stainless steel Immersion stem: nickel-plated brass (standard length only); optional 316L stainless steel
FILL	Models 1BS/BC are solvent filled, models 2-8 non-toxic oil filled
TEMPERATURE DEADBAND	Type F typically 1% and type B, C, and E typically 2% of range under laboratory conditions (70°F ambient circulating bath at rate of 1/2°F per minute change)
HEAT TRACING OR FREEZE PROTECTION	Thermostats designed specifically for heat tracing and freeze protection ambient sensing applications are available with types B100 and E100; specifications are the same as above except: type B100-13546 includes: E/R: 22 A/480 VAC switch; type E100-13545 includes: 22 A/480 VAC switch and 10 feet of stainless steel capillary

APPROVALS



UL listed
 Temperature: UL 873, file # E10667
 Pressure: UL 508, file # E42272



CSA certified
 Temperature: C22.2, no. 24 file # LR7814
 Pressure: C22.2, no. 14 file # LR39690



CE Compliance with Low Voltage Directive (LVD)
 CE Compliance with Pressure Equipment Directive (PED 97/23/EC)

PRESSURE MODEL CHART

Model	Adjustable Set Point Range		Deadband		Over Range Pressure*		Proof Pressure**	
	Low end of range on fall; High end of range on rise							
Type H100	"wc	mbar	"wc	mbar	psi	bar	psi	bar
Buna N diaphragm and O-Ring with 1/2" NPT (female) aluminum pressure connection (other wetted materials available see page 9)								
520	300 Vac to 0	-746,7 to 0	0.2 to 8	0,5 to 19,9	200	13,8	400	27,6
521	10 Vac to 10	-24,9 to 24,9	0.1 to 0.6	0,2 to 1,5	200	13,8	400	27,6
522	50 Vac to 50	-124,5 to 124,5	0.1 to 3	0,2 to 7,5	200	13,8	400	27,6
523	0.5 to 5.0	1,2 to 12,4	0.1 to 0.3	0,2 to 0,75	200	13,8	400	27,6
524	2.5 to 50	6,2 to 124,5	0.1 to 0.8	0,2 to 2,0	200	13,8	400	27,6
525	10 to 250	24,9 to 622,3	0.1 to 6	0,2 to 24,9	200	13,8	400	27,6
Welded 316L stainless steel diaphragm with 1/2" NPT (female) 316L pressure connection								
530	300 Vac to 0	-746,7 to 0	0.2 to 15	0,5 to 37,3	50	3,4	100	6,9
531	10 Vac to 10	-24,9 to 24,9	0.1 to 0.6	0,2 to 1,5	50	3,4	100	6,9
532	50 Vac to 50	-124,5 to 124,5	0.1 to 3	0,2 to 7,5	50	3,4	100	6,9
533	0.5 to 5.0	1,2 to 12,4	0.1 to 0.3	0,2 to 0,7	50	3,4	100	6,9
534	2.5 to 50	6,2 to 124,5	0.1 to 0.8	0,2 to 2,0	50	3,4	100	6,9
535	10 to 250	24,9 to 622,3	0.1 to 10	0,2 to 24,9	50	3,4	100	6,9
	psi	bar	psi	bar	psi	bar	psi	bar
Welded 316L stainless steel diaphragm with 1/2" NPT (female) pressure connection, large 0.72" orifice for clean-out purposes								
171	1 to 20	0,07 to 1,4	0.1 to 1	0,01 to 0,07	500	34,5	1000	68,9
172	2 to 50	0,14 to 3,4	0.1 to 1.5	0,01 to 0,10	500	34,5	1000	68,9
173	4 to 100	0,3 to 6,9	0.1 to 2.5	0,01 to 0,17	500	34,5	1000	68,9
174	8 to 200	0,6 to 13,7	0.1 to 3.5	0,01 to 0,24	500	34,5	1000	68,9
2" sanitary welded 316L stainless steel diaphragm and pressure connection. Mates with Tri-Clamp® fitting systems								
560	0.5 to 15	0,03 to 1,03	0.1 to 1	0,01 to 0,07	200	13,8	300	20,7
561	1 to 25	0,07 to 1,72	0.1 to 1.5	0,01 to 0,10	200	13,8	300	20,7
562	2 to 50	0,14 to 3,45	0.1 to 2.5	0,01 to 0,17	200	13,8	300	20,7
563	4 to 100	0,3 to 6,9	0.1 to 4	0,01 to 0,2	200	13,8	300	20,7
564	8 to 200	10,6 to 13,8	0.1 to 5	0,01 to 0,3	200	13,8	300	20,7

Tri-Clamp® is a registered trademark of Tri-Clover Inc.

Application Note: The use of metallic diaphragms where higher pressure shock or heavy cycling is expected should be avoided. Models 171-174 should not be used where system or start-up vacuum pressure might exceed 26" Hg Vac (-0.9 bar). Use of optional diaphragm materials for models 483-489 may increase deadband.

Model	Adjustable Set Point Range		Deadband		Over Range Pressure*		Proof Pressure**			
	Low end of range on fall; High end of range on rise									
Type H100	psi	bar	psi	bar	psi	bar	psi	bar		
1.5" sanitary welded 316L stainless steel diaphragm and pressure connection. Mates with Tri-Clamp fitting systems										
565	5 to 30	0,3 to 2,1	1 to 5	0,07 to 0,3	1000	68,9	1500	103,4		
566	10 to 100	0,7 to 6,9	1 to 12	0,07 to 0,8	1000	68,9	1500	103,4		
567	15 to 300	1,0 to 20,7	3 to 22	0,21 to 1,5	1000	68,9	1500	103,4		
Buna N diaphragm and O-Ring with 1/4" NPT (female) nickel-plated brass pressure connection; Option M540 Viton® diaphragm and O-Ring available for models 701-705										
701	1.5 to 30	0,1 to 2	1 to 2	0,07 to 0,14	500	34,5	600	41,4		
702	3 to 100	0,2 to 6,9	1 to 4	0,07 to 0,28	500	34,5	600	41,4		
703	9 to 300	0,7 to 20,7	1 to 5	0,07 to 0,34	500	34,5	600	41,4		
704	15 to 500	1,0 to 34,5	2 to 8	0,14 to 0,55	1500	103,4	2500	172,4		
705	30 to 1000	2,1 to 69	3 to 20	0,21 to 1,38	1500	103,4	2500	172,4		
706	100 to 1700	6,9 to 117	10 to 30	0,07 to 2,07	2000	137,9	2500	172,4		
316L stainless steel diaphragm (optional Hastelloy® C, Monel® or Tantalum); Viton® GLT O-Ring (optional Kalrez®, Silicone, Ethylene Propylene, or Aflas®); 316 stainless steel 1/2" NPT (female) pressure connection (optional Hastelloy® B or C, or Monel®), large 0.72" orifice for clean-out purposes. Models 188 and 189 have a 316L stainless steel 1/2" NPT (female) pressure connection										
183	1 to 20	0,07 to 1,4	0.3 to 2.5	0,021 to 0,17	500	34,5	1000	68,9		
184	2 to 50	0,14 to 3,4	0.3 to 3	0,021 to 0,2	500	34,5	1000	68,9		
185	4 to 100	0,3 to 6,9	0.5 to 6	0,03 to 0,4	500	34,5	1000	68,9		
186	8 to 200	0,6 to 13,8	1 to 11	0,07 to 0,8	500	34,5	1000	68,9		
188	50 to 1000	3,45 to 68,9	25 to 125	1,7 to 8,6	2000	137,9	7000	482,6		
189	250 to 3500	17,3 to 241,3	50 to 300	3,4 to 20,7	4000	275,8	7000	482,6		
Welded 316 stainless steel diaphragm with 1/2" NPT (female) pressure connection, large 0.72" orifice for clean-out purposes										
			Lower 75% range span		Top 25% range span					
	psi	bar	psi	bar	psi	bar	psi	bar	psi	bar
190	5 to 30	0,3 to 2,1	1 to 3	0,07 to 0,2	6 max	0,4	1500	103,4	2500	172,4
191	10 to 100	0,7 to 6,9	1 to 8	0,07 to 0,6	15 max	1,0	1500	103,4	2500	172,4
192	15 to 300	1 to 20,7	3 to 18	0,2 to 1,2	25 max	1,7	1500	103,4	2500	172,4
193	20 to 500	1,4 to 34,5	4 to 30	0,3 to 2,1	45 max	3,1	1500	103,4	2500	172,4
194	80 to 1700	5,5 to 117,2	5 to 120	0,3 to 8,3	150 max	10,3	2000	137,9	2500	172,4
Welded 316 stainless steel diaphragm with 1/2" NPT (female) pressure connection, 0.06" orifice to dampen pulsations										
490	5 to 30	0,3 to 2,1	1 to 3	0,07 to 0,2	6 max	0,4	1500	103,4	2500	172,4
491	10 to 100	0,7 to 6,9	1 to 8	0,07 to 0,6	15 max	1,0	1500	103,4	2500	172,4
492	15 to 300	1 to 20,7	3 to 18	0,2 to 1,2	25 max	1,7	1500	103,4	2500	172,4
493	20 to 500	1,4 to 34,5	4 to 30	0,3 to 2,1	45 max	3,1	1500	103,4	2500	172,4
494	80 to 1700	5,5 to 117,2	5 to 120	0,3 to 8,3	150 max	10,3	2000	137,9	2500	172,4

Hastelloy® is a registered trademark of Haynes International, Inc.

Monel® is a registered trademark of the INCO family of companies.

Viton® and Kalrez® are registered trademarks of Dupont Dow Elastomers.

Aflas® is a registered trademark of Asahi Glass, Inc.

* **Over Range Pressure:** The maximum pressure that may be applied continuously without causing damage and maintaining set point repeatability.

** **Proof Pressure:** The maximum pressure to which a pressure sensor may be occasionally subjected, which causes no permanent damage. The unit may require calibration (e.g., start-up, testing).

Deadband Note: Models 190-194, 490-494 are expressed as the lower 75% and top 25% of the range span because of the operating characteristics of the diaphragm sensor and switch.

PRESSURE MODEL CHART

Model	Adjustable Set Point Range		Deadband		Over Range Pressure*		Proof Pressure**	
	Low end of range on fall; High end of range on rise							
	psi	bar	psi	bar	psi	bar	psi	bar
Type H100	(unless noted)		(unless noted)					
316L stainless steel diaphragm (optional Hastelloy® C, Monel® or Tantalum) Viton® GLT O-Ring (optional Kalrez®, Silicone, ethylene propylene or Aflas®), 316 stainless steel 1/2" NPT (female) pressure connection (optional Hastelloy® B or C, or Monel®), 0.06" orifice. Models 488 and 489 316L pressure connection								
483	1 to 20	0,07 to 1,4	0.3 to 2.5	0,02 to 0,17	500	34,5	1000	68,9
484	2 to 50	0,14 to 3,4	0.3 to 3	0,02 to 0,2	500	34,5	1000	68,9
485	4 to 100	0,3 to 6,9	0.5 to 6	0,03 to 0,4	500	34,5	1000	68,9
486	8 to 200	0,6 to 13,8	1 to 11	0,07 to 0,8	500	34,5	1000	68,9
488	50 to 1000	3,4 to 68,9	25 to 125	1,7 to 8,6	2000	137,9	7000	482,6
489	250 to 3500	17,2 to 241,3	50 to 300	3,4 to 20,7	4000	275,8	7000	482,6
Phosphor bronze bellows with 1/4" NPT (female) nickel-plated brass pressure connection. Model 218 has 300 series stainless steel spring in media								
218	30 "Hg Vac to 0	-1 to 0	1 to 2 "Hg	0,03 to 0,07	0	0	30	2,07
270	4 to 200	0,3 to 13,8	1 to 8	0,07 to 0,6	200	13,8	250	17,2
274	6 to 300	0,4 to 20,7	1 to 10	0,07 to 0,7	300	20,7	350	24,1
Welded 316L stainless steel bellows with 1/4" NPT (female) pressure connection								
358	15 to 200	1 to 13,8	1 to 3	0,07 to 0,2	200	13,8	800	55,2
361	20 to 300	1,38 to 20,7	1 to 4	0,07 to 0,3	300	20,7	800	55,2
376	25 to 500	1,8 to 34,5	1.5 to 5	0,10 to 0,3	500	34,5	800	55,2
303 stainless steel piston, Buna N O-Ring with 1/4" NPT (female) 303 stainless steel pressure connection (Not recommended for gas service since drying of O-Ring seal can allow bleeding of medium into the atmosphere)								
610	75 to 1000	5,2 to 68,9	30 to 150	2,07 to 10,3	6000	413,7	10,000	689,5
612	125 to 3000	8,6 to 206	40 to 250	2,76 to 17,2	6000	413,7	10,000	689,5
616	700 to 5000	48,5 to 344	40 to 375	2,76 to 25,9	6000	413,7	10,000	689,5
316 stainless steel bellows with 1/4" NPT (female) pressure connection (Not recommended for gas applications or for rapid or high cycling pressure changes)								
680	100 to 1700	6,9 to 117,2	9 to 40	0,6 to 2,8	1700	117,2	2500	172,4

DIFFERENTIAL PRESSURE MODEL CHART

Model	Adjustable Set Point Range		Deadband		Working Pressure***		Proof Pressure**	
	Low end of range on fall; High end of range on rise							
	"wcd/psid	mbar/bar	"wc/psi	mbar/bar	psi	bar	psi	bar
Type H100K								
Kapton® Diaphragm, Buna N Sealing diaphragms and epoxy coated aluminum 1/8" NPT (female) pressure connections								
540	0.2 to 7 "wcd	0,5 to 17,4 mbar	0.05 to 0.6 "wc	0,1 to 1,5 mbar	200	13,8	400	27,6
541	1 to 20 "wcd	2,5 to 49,7 mbar	0.1 to 1.0 "wc	0.2 to 2,5 mbar	200	13,8	400	27,6
542	5 to 50 "wcd	12,4 to 124,4 mbar	0.2 to 2.5 "wc	0,5 to 6,2 mbar	200	13,8	400	27,6
543	10 to 200 "wcd	24,9 to 497,0 mbar	0.5 to 8 "wc	1,2 to 19,9 mbar	200	13,8	400	27,6
544	2 to 20 psid	0,1 to 1,4 bar	0.1 to 1.3 psi	6,9 to 89,6 mbar	1200	82,7	2500	172,4
545	5 to 50 psid	0,3 to 3,4 bar	0.2 to 2.2 psi	0 to 0,15 bar	1200	82,7	2500	172,4
546	10 to 125 psid	0,7 to 8,6 bar	0.4 to 5.0 psi	0 to 0,34 bar	1200	82,7	2500	172,4
547	50 to 250 psid	3,4 to 17,2 bar	0.8 to 10 psi	0,1 to 0,69 bar	1200	82,7	2500	172,4
548	100 to 500 psid	6,9 to 34,5 bar	2.0 to 15 psi	0,1 to 1,03 bar	1200	82,7	2500	172,4

Kapton® is a registered trademark of E.I. DuPont.

TEMPERATURE MODEL CHART

Model	Adjustable Set Point Range		Max. Temp		Scale Division		Stem/Bulb Size‡
	°F	°C	°F	°C	°F	°C	
Type B100 Internal adjustment via reference dial							
Type C100 No reference dial; model 13546 not available							
120	0 to 225	-17.8 to 107.2	275	135	10	5	9/16" x 1/8" below 1/2 "NPT thread (nickel-plated brass)
121	200 to 425	93.3 to 218.3	475	246.1	10	5	9/16" x 1/8" below 1/2 "NPT thread (nickel-plated brass)
13546	15 to 140	-9.4 to 60	60	71.1	5	2	9/16" x 2 1/16" long stainless steel (Freeze Protection)
Type E100 Stainless steel bulb and capillary; internal adjustment via reference dial							
2BSA	-120 to 100	-84.4 to 37.8	150	65.5	10	5	3/8 x 2 5/8"
2BSB	30 to 250	-1.1 to 121.1	300	148.9	10	5	3/8 x 2 5/8"
3BS	100 to 400	37.8 to 201.1	450	232.2	10	5	3/8 x 2 1/8"
4BS	25 to 100	-3.9 to 37.8	150	65.5	2	1	3/8 x 6 3/4"
5BS	-20 to 80	-28.9 to 26.7	130	54.4	5	2	3/8 x 5"
8BS	350 to 640	176.7 to 337.8	690	365.6	10	5	3/8 x 3 1/4"
13545	25 to 325	-3.9 to 162.8	360	182.2	10	5	1/8 x 11 3/8" (Heat Tracing)
Copper bulb and capillary							
2BCA	-120 to 100	84.4 to 37.8	150	65.5	10	5	3/8 x 2 5/8"
2BCB	30 to 250	-1.1 to 121.1	300	18.9	10	5	3/8 x 2 5/8"
3BC	100 to 400	37.8 to 204.4	450	232.2	10	5	3/8 x 2 1/8"
4BC	25 to 100	-3.9 to 37.7	150	65.5	2	1	3/8 x 6 3/4"
5BC	-20 to 80	-28.9 to 26.7	130	54.4	5	2	3/8 x 5"
8BC	350 to 640	176.7 to 337.8	690	365.6	10	5	3/8 x 3 1/4"
Type F100 Stainless steel bulb and capillary; no reference dial							
1BS	-180 to 120	-117.8 to 48.9	170	76.6	N/A		3/8 x 3 3/4"
2BS	-125 to 350	-87.2 to 176.7	400	204.4	N/A		3/8 x 2 5/8"
3BS	-125 to 500	-87.2 to 260	550	287.8	N/A		3/8 x 2 1/8"
4BS	-40 to 120	-40 to 48.9	170	76.6	N/A		3/8 x 6 3/4"
5BS	-40 to 180	-40 to 82.2	230	110	N/A		3/8 x 5"
6BS	0 to 250	-17.8 to 121.1	300	148.8	N/A		3/8 x 4 1/2"
7BS	0 to 400	-17.8 to 204.4	450	232.2	N/A		3/8 x 3"
8BS	50 to 650	10 to 343.3	700	371.1	N/A		3/8 x 3 1/4"
Copper bulb and capillary							
1BC	-180 to 120	-117.8 to 48.9	170	76.6	N/A		3/8 x 3 3/4"
2BC	-125 to 350	-87.2 to 176.7	400	204.4	N/A		3/8 x 2 5/8"
3BC	-125 to 500	-87.2 to 260	550	287.8	N/A		3/8 x 2 1/8"
4BC	-40 to 120	-40 to 48.9	170	76.6	N/A		3/8 x 6 3/4"
5BC	-40 to 180	-40 to 82.2	230	110	N/A		3/8 x 5"
6BC	0 to 250	-17.8 to 121.1	300	148.8	N/A		3/8 x 4 1/2"
7BC	0 to 400	-17.8 to 204.4	450	232.2	N/A		3/8 x 3"
8BC	50 to 650	10 to 343.3	700	371.1	N/A		3/8 x 3 1/4"

‡Optional immersion stem lengths and capillary lengths are available.

* **Over Range Pressure:** The maximum pressure that may be applied continuously without causing damage and maintaining set point repeatability.

** **Proof Pressure:** The maximum pressure to which a pressure sensor may be occasionally subjected, which causes no permanent damage. The unit may require calibration (e.g. start-up, testing).

*** **Working Pressure Range:** The pressure range within which two opposing sensors can be safely operated and still maintain set point adjustability provided the difference in pressure between them does not exceed the designated adjustable range.

HOW TO ORDER

BUILDING A PART NUMBER

Select a **Type**

Refer to the "Type" section below.

Determine type number based on switch output, enclosure, adjustment and reference.

Fill in the type portion of your part number with the corresponding number.

Select a **Model**

Refer to the "Model Charts".

Determine model based on adjustable range, deadband and proof pressure.

Fill in the model portion of your part number with the corresponding number.

Select an **Option**

Refer to the "Options" section.

Determine option number based on switch output, optional materials or other product enhancements.

Fill in the option portion of your part number with the corresponding number.

Leave "option" portion a blank if no options are needed.

FOR MULTIPLE OPTIONS: Call United Electric Controls.

TYPE

DESCRIPTION

PRESSURE

Type H100 - One SPDT output; epoxy coated enclosure; internal adjustment with "High-Low" reference scale

DIFFERENTIAL PRESSURE

Type H100K- One SPDT output; epoxy coated enclosure; internal adjustment with "High-Low" reference scale

TEMPERATURE

Type B100 - Immersion stem; one SPDT output; internal adjustment with reference dial

Type C100 - Immersion stem; one SPDT output; internal adjustment with no reference scale

Type E100 - Bulb and capillary; one SPDT output; internal adjustment with reference dial

Type F100 - Bulb and capillary; one SPDT output; internal adjustment with no reference scale

SWITCH OPTIONS

0140

Gold contacts, 1 A 125 VAC resistive

0500

Close deadband, 5 A 125/250 VAC resistive.

NOT AVAILABLE MODELS 520-535

1010

DPDT switch, 10 A 125/250 VAC resistive; deadband and minimum set point will increase.

NOT AVAILABLE TEMPERATURE VERSIONS, TYPE H100K OR MODELS 171-194, 483-567 AND MODEL 680

1070

10 A 125 VDC resistive; deadband and minimum set point will increase.

NOT AVAILABLE MODELS 171-194, 483-567

1519

Adjustable deadband, 15 A 125/250/480 VAC resistive; adjustment wheel changes rise setting only. If adjustment on fall setting is required, use primary adjustment.

NOT AVAILABLE TYPES B100, E100 OR MODELS 171-194, 483-567, 610-616

1530

External manual reset, 15 A 125/250/480 VAC resistive; latches on rise.

NOT AVAILABLE MODELS 520-535

1535

High ambient, 15 A 125/250 VAC resistive; temperatures up to 250°F (145°C).

NOT AVAILABLE ON MODELS 520-535

1537

Vapor sealed switch, 15 A 125/250 VAC resistive. NOT AVAILABLE ON MODELS 520-535

2000

20 A 125/250/300 VAC resistive. NOT AVAILABLE TYPE H100K OR MODELS 520-535

3000

30 A 125/250/300 VAC resistive. NOT AVAILABLE TYPE H100K OR MODELS 171-194, 483-567, 680

OTHER OPTIONS

M020	Red status light, 115 VAC only. "Field Wired"
M201	Factory set one switch; specify increasing or decreasing pressure or temperature and setpoint
M276	Range indicated on nameplate in bars/mbars. NOT AVAILABLE ON TEMPERATURE VERSIONS
M278	Range indicated on nameplate in Kg/cm ² . NOT AVAILABLE ON TEMPERATURE VERSIONS
M405	Intrinsic safety compliance per EN50014, EN50020, EEx i2 II T6
M407	CE compliance to Pressure Equipment Directive (category IV)
M444	Paper ID tag
M446	Stainless steel ID tag & wire attachment
M504	316L stainless steel immersion stem. AVAILABLE ON MODELS 120, 121 ONLY
6361-704	Surface and Pipe Mounting Hardware (required for model 520-535, 540-548 when surface mounting)
M540	Viton® construction (deadband and low end range may increase slightly); wetted parts include Viton® diaphragm and O-ring plus stainless steel pressure connection. ON MODELS 610-616 (O-RING ONLY), 701-705, Kapton® diaphragm, Viton® O-Ring and sealing diaphragms and aluminum pressure connections ON MODELS 540-548
M550	Oxygen service cleaning; internal construction may change

OPTIONAL SENSOR MATERIAL FOR "WC RANGES. AVAILABLE MODELS 520-525

XC001	Aluminum pressure connection, Viton® diaphragm, Viton® O-ring
XC002	Aluminum pressure connection, Kapton® diaphragm, Buna N O-ring
XC003	Aluminum pressure connection, Kapton® diaphragm, Viton® O-ring
XC004	316L Stainless steel pressure connection, 316L stainless steel diaphragm, Viton® O-ring. (Over range pressure is limited to 100 psi)
XC005	316L Stainless steel pressure connection, Viton® diaphragm, Viton® O-ring
XC006	316L Stainless steel pressure connection, Kapton® diaphragm, Viton® O-ring
XC007	316L Stainless steel pressure connection, Teflon® diaphragm, Viton® O-ring

OPTIONAL SENSOR MATERIALS FOR CORROSIVE MEDIA. AVAILABLE MODELS 183-189, 483-489

XD002	Hastelloy C diaphragm
XD003	Monel diaphragm
XD004	Tantalum diaphragm
XP111	Hastelloy B pressure connection
XP112	Hastelloy C pressure connection
XP113	Monel pressure connection
XR211	Kalrez® O-ring
XR212	Silicone O-ring. NOT AVAILABLE MODELS 188-189, 488-489
XR213	Ethylene propylene O-ring
XR214	Aflas® O-ring

OPTIONAL FLUSH MOUNT FLANGES. AVAILABLE MODELS 560-567

F196	Flush mounted flange, 150#, 1" lap joint, raised face AVAILABLE MODELS 565-567 ONLY
F197	Flush mounted flange, 150#, 2" lap joint, raised face AVAILABLE MODELS 560-564 ONLY
F198	Flush mounted flange, 300#, 1" lap joint, raised face AVAILABLE MODELS 565-567 ONLY
F199	Flush mounted flange, 300#, 2" lap joint, raised face AVAILABLE MODELS 560-564 ONLY

Other flanges (150# and 300#) available, please consult UE. Flanges conform to ANSI B16.5. Maximum pressure is limited by flange rating.

Note: No options are available on Heat Trace and Freeze Protection Models 13546 and 13545 except M201, M444 and M446.

OPTIONS FOR TEMPERATURE MODELS

UNION CONNECTORS

Option	Replacement Number	Description
<u>Brass</u>		
W027	SD6213-27	½" NPT w/ ¾" bushing
W045	SD6213-45	¾" NPT
W051	SD6213-51	½" NPT
<u>304 Stainless Steel</u>		
W028	SD6213-28	½" NPT w/ ¾" bushing
W046	SD6213-46	¾" NPT
W050	SD6213-50	½" NPT

THERMOWELLS

For all bulb & capillary switches, except Model 13545

<u>Brass</u>		
W075	SD6225-75	½" NPT with ¾" NPT adapter bushing, 4" BT
W191	SD6225-191	½" NPT, 4" BT
W118	SD6225-118	½" NPT with ¾" NPT adapter bushing, 7" BT
W192	SD6225-192	½" NPT, 7" BT
<u>316 Stainless Steel</u>		
W076	SD6225-76	¾" NPT, 4.5" BT
W193	SD6225-193	½" NPT, 4.5" BT
W119	SD6225-119	¾" NPT, 7.5" BT
W177	SD6225-177	½" NPT, 7.5" BT

For all immersion stem switches; except Model 13546

W139	SD6225-139	¾" NPT X 1 23/32" BT, BRASS
W140	SD6225-140	¾" NPT X 1 23/32" BT, 316 ST/ST

W000 IMMERSION STEM AND THERMOWELLS

Note: Option W000 is a special Immersion Stem construction that has no external thread. This option fits inside a special thermowell and is secured with a set-screw.

Option	Description
W000	Immersion stem only, Brass
W097	Immersion stem and thermowell. Includes W000 stem and ½" NPT x 1 23/32" BT Brass thermowell
W099	Immersion stem and thermowell. Includes W000 stem and ½" NPT x 1 23/32" BT 316 st/st thermowell.

OPTIONAL LENGTHS:

Optional immersion stem lengths to 15" available in brass, with or without 316 st/st thermowell. Consult UE for additional information. Optional capillary length to *50' available in copper or 304 st/st. Armor or Teflon® capillary protection available to lengths less than or equal to capillary length. Consult UE for additional information.

*Consult UE regarding repeatability and ambient effects on capillary lengths over 30'.

DIMENSIONAL DRAWINGS

Types B100, C100, E100, F100, H100, H100K

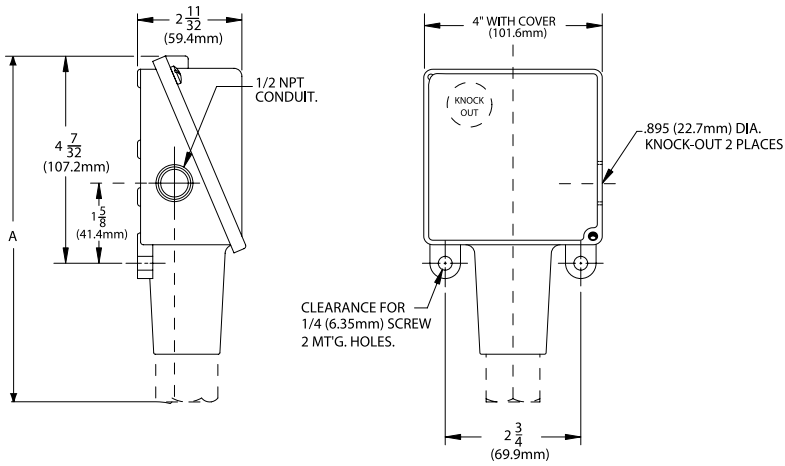

Dimension A			
Models	Inches	mm	NPT
Pressure			
171-174	7.50	190,57	1/2
183-186	7.56	192,07	1/2
188, 189	6.63	168,27	1/2
190-194	6.63	168,27	1/2
218-274	6.56	166,67	1/4
358-376	7.03	176,99	1/4
483-486	7.56	192,07	1/2
488, 489	6.63	168,27	1/2
490-494	6.63	168,27	1/2
520-525	8.44	214,30	1/2
530-535	8.00	203,20	1/2
560-564	6.62	168,3	2" Sanitary Fitting
565-567	6.62	168,3	1 1/2" Sanitary Fitting
610-616	7.00	177,80	1/4
680	6.97	177,04	1/4
701-706	6.56	166,67	1/4
Temperature			
120,121, 13546	10.44	265,10	Immersion stem
18C-8BC, 18S-8BS, 13545,	8.75	222,23	Bulb & capillary
Differential Pressure			
540-548	8.34	216.6	1/8

All dimensions stated in inches (millimeters)

Temperature Sensors

Models 18C-8BC, 18S-8BS, 13545

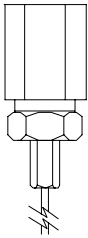

Models 120,121

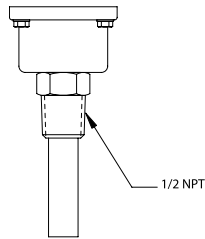

Model 13546

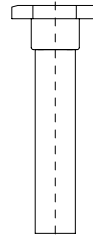

Pressure Sensors

Models 171-174

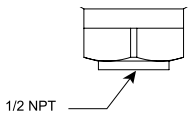

Models 183-186, 483-486

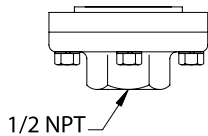

Models 188-194, 488-494

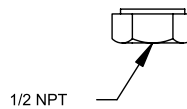

Models 218-376, 610-706

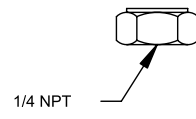

Models 520-525

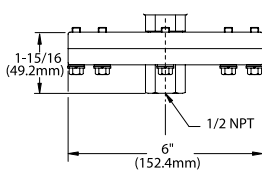

Models 530-535

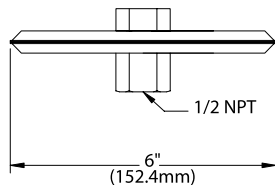

Models 540-543

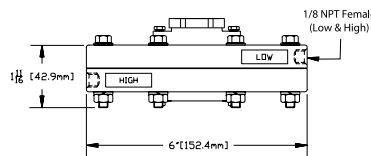

Models 544-548

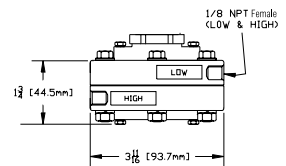

Models 560-564

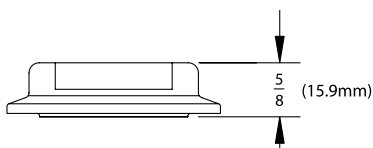

Models 565-567

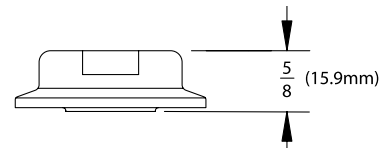

RECOMMENDED PRACTICES AND WARNINGS

United Electric Controls Company recommends careful consideration of the following factors when specifying and installing UE pressure and temperature units. Before installing a unit, the Installation and Maintenance instructions provided with unit must be read and understood.

- To avoid damaging unit, proof pressure and maximum temperature limits stated in literature and on nameplates must never be exceeded, even by surges in the system. Operation of the unit up to maximum temperature is acceptable on a limited basis (i.e., start-up, testing) but continuous operation must be restricted to the designated adjustable range. Excessive cycling at maximum temperature limits could reduce sensor life.
- A back-up unit is necessary for applications where damage to a primary unit could endanger life, limb or property. A high or low limit switch is necessary for applications where a dangerous runaway condition could result.
- The adjustable range must be selected so that incorrect, inadvertent or malicious setting at any range point cannot result in an unsafe system condition.
- Install unit where shock, vibration and ambient temperature fluctuations will not damage unit or affect operation. Orient unit so that moisture does not enter the enclosure via the electrical connection. When appropriate, this entry point should be sealed to prevent moisture entry.
- Unit must not be altered or modified after shipment. Consult UE if modification is necessary.
- Monitor operation to observe warning signs of possible damage to unit, such as drift in set point or faulty display. Check unit immediately.
- Preventative maintenance and periodic testing is necessary for critical applications where damage could endanger property or personnel.
- For all applications, a factory set unit should be tested before use.
- Electrical ratings stated in literature and on nameplate must not be exceeded. Overload on a switch can cause damage, even on the first cycle. Wire unit according to local and national electrical codes, using wire size recommended in installation sheet.
- Do not mount unit in ambient temp. exceeding published limits.

LIMITED WARRANTY

Seller warrants that the product hereby purchased is, upon delivery, free from defects in material and workmanship and that any such product which is found to be defective in such workmanship or material will be repaired or replaced by Seller (F.O.B. UE Watertown); provided, however, that this warranty applies only to equipment found to be so defective within a period of 18 months from the date of manufacture by the Seller. Seller shall not be obligated under this warranty for alleged defects which examination discloses are due to tampering, misuse, neglect, improper storage, and in any case where products are disassembled by anyone other than authorized Seller's representatives.

EXCEPT FOR THE LIMITED WARRANTY OF REPAIR AND REPLACEMENT STATED ABOVE, SELLER DISCLAIMS ALL WARRANTIES WHATSOEVER WITH RESPECT TO THE PRODUCT, INCLUDING ALL IMPLIED WARRANTIES OF MERCHANTABILITY OR FITNESS FOR ANY PARTICULAR PURPOSE.

LIABILITY LIMITATION

SELLER'S LIABILITY TO BUYER FOR ANY LOSS OR CLAIM, INCLUDING LIABILITY INCURRED IN CONNECTION WITH (I) BREACH OF ANY WARRANTY WHATSOEVER EXPRESSED OR IMPLIED, (II) A BREACH OF CONTRACT, (III) A NEGLIGENT ACT OR ACTS (OR NEGLIGENT FAILURE TO ACT) COMMITTED BY SELLER, OR (IV) AN ACT FOR WHICH STRICT LIABILITY WILL BE IMPUTED TO SELLER, IS LIMITED TO THE LIMITED WARRANTY OF REPAIR AND REPLACEMENT STATED HEREIN. IN NO EVENT SHALL THE SELLER BE LIABLE FOR ANY SPECIAL, INDIRECT, CONSEQUENTIAL OR OTHER DAMAGES OF A LIKE GENERAL NATURE, INCLUDING, WITHOUT LIMITATION, LOSS OF PROFITS OR PRODUCTION, OR LOSS OR EXPENSES OF ANY NATURE INCURRED BY THE BUYER OR ANY THIRD PARTY.

UE specifications subject to change without notice.

