

IntelliPoint RF™ Series

Point Level Switch



The **IntelliPoint RF** From

DREXELBROOK™

*The Only RF Switch
You Won't Calibrate!*

Intelligent Electronics

- No calibration or setpoint adjustments.
- Ignores changes in dielectric or conductivity.
- Automatically recognizes and ignores coatings to prevent false alarms.
- Continuous self-test monitors circuits and sensing elements for faults.
- Universal power supply automatically detects input power source.

Diverse Applications

- Detects the absence or presence of liquids, slurries, interfaces and granulars.

Output

- (2) SPDT relays; relay#2 can be configured as an alarm or fault.

Dual Compartment Housing

- Power Supply is isolated from intrinsically-safe sensing element and circuit board.

No Calibration

The only RF switch you won't calibrate. Simply install the IntelliPoint RF Series into the tank and apply power...that's it! Unlike other RF or capacitance systems that require calibration via setpoint potentiometers, jumpers, magnets, or pushbuttons, the IntelliPoint RF Series reliably detects the absence or presence of material without any adjustments.

The IntelliPoint RF Series software continuously monitors the application for changes in composition, dielectric or conductivity, and maintains a repeatable trip point on the probe. Other RF and capacitance systems require calibration adjustments when the process material is changed. Since the IntelliPoint RF Series recognizes changes in material, it is ideal for non-dedicated tanks that are used for a wide variety of products.

Universal Power Supply

The IntelliPoint electronics use a universal power supply module that can be powered from a 85 to 250 Vac or 21 to 100 Vdc supply without moving jumpers.

Self-Test Feature

Automatic and manual self-test functions ensure proper system operation. An AutoVerify™ self-check circuit continuously monitors that the complete system is functioning properly. The Manual Certify not only checks the function of the system, but also checks the AutoVerify self-test circuits to make sure that they are also working properly.

Dual Compartment Housing

New dual compartment housing separates the customer wiring and power supply from the sensing element and operating circuits. The encapsulated power supply/terminal block design eliminates the possibility of damage caused by moisture in the conduit.

Specifications

Technology:
RF Admittance.

Calibration:
None.

Modes Of Operation:
High and Low Level.

Repeatability:
2 mm (0.08 inch) conductive liquids.

Response Time:
less than one second.

Ambient Electronic Temperature:
-30 to 70°C (-28 to 158°F).

Storage Temperature:
-40 to 85°C (-40 to 185°F).

Indicators:
LEDs: Green Power, Red Relay 1, Red Relay 2.

Self-Check:
AutoVerify automatically and continuously checks electronics and sensing element for faults. Manual Certify checks that the AutoVerify circuits are functioning.

Time Delay:
0-60 seconds, forward or reverse-acting.

Supply Voltage:
85-250 Vac
21-100 Vdc auto-detecting without jumpers
DC to 400 Hz.

Power Consumption:
2 watts maximum.

Relay Contacts:
(2) SPDT.

Maximum Contact Load:
5A/30 Vdc.
5A/250 Vac.

Maximum Switching Capacity:
2000 VA/150 Watt.



Minimum Contact Load (DC):
100 mA/12 Vdc.

Housing:
Dual Compartment, Powder-Coated aluminum with two cable entries.

Cable Entry:
M20 x 1.5 CENELEC
¾-inch NPT FM/CSA.

Ingress Protection:
IP66 NEMA 4X.

Approvals:

 II 1/2 GD EEx d[ia] IIC T5...T2
 T90°C KEMA 01 ATEX 2187X  0344



Explosionproof for Class I, Division 1, Groups A, B, C and D; Dust-Ignitionproof for Class II, III, Division 1, Groups E, F and G; Nonincendive for Class I, Division 2, Groups A, B, C & D; Suitable for Class II, III, Groups F & G hazardous outdoor Type 4X, IP66 (classified) locations with Intrinsically Safe connections to Class I, II, III, Division 1, Groups A, B, C, D, E, F and G hazardous (classified) locations in accordance with Control Drawing 420-0004-144-CD.

Wiring

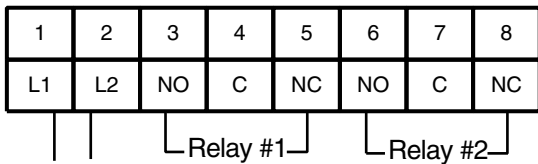

85 to 250 Vac
21 to 100 Vdc
Auto-Detecting

Dimensions

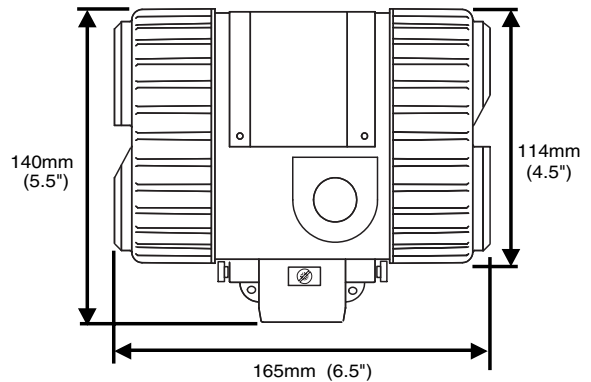

Model Numbering

IntelliPoint RF™

Technology				
R	RF Admittance			
Measurement Type				
N	No Calibration, Point Level			
Input				
L	Universal Power Supply 21-100 Vdc, 85-250 Vac, 0-400 Hz			
Housing				
0	No Approvals, Dual Compartment NEMA 4X/IP66, M20 x 1.5 conduit entries			
1	No Approvals, Dual Compartment NEMA 4X/IP66 ¾" NPT conduit entries			
2	CENELEC/ATEX Approved, Dual Compartment NEMA 4X/IP66 M20x1.5 conduit entries			
3	FM/CSA Approved, Dual Compartment NEMA 4X/IP66 ¾" NPT conduit entries			
Electronics				
0	Integral			
1	Remote, no cable			
2	Remote with 3 m (10 feet) cable			
3	Remote with 7.6 m (25 feet) cable			
4	Remote with 10.6 m (35 feet) cable			
5	Remote with 15.2 m (50 feet) cable			
6	Remote with 23 m (75 feet) cable			
Output				
1	Two SPDT Relays, relay #2 configured as alarm or fault			
Sensing Element continued on next page				
	Application	Sensing Element	Pressure/Temperature	Wetted Parts
00	General purpose	700-1202-001 remote 700-1202-021 integral	13.8 bar @ 232°C (200 PSI @ 450°F)	316SS and PEEK
01	Floating roof with cable attachment and brass bottom weight	700-1202-012 remote 700-1202-022 integral	13.8 bar @ 177°C (200 PSI @ 350°F)	316SS, Brass, and PEEK
02	General purpose, longer insertion lengths with cable attachment and 316SS bottom weight	700-1202-014 remote 700-1202-024 integral	13.8 bar @ 177°C (200 PSI @ 350°F)	316SS and PEEK
03	Proximity	700-1202-018 remote 700-1202-028 integral	13.8 bar @ 232°C (200 PSI @ 450°F)	316SS and PEEK with 76 mm (3) 316SS proximity plate
04	General purpose, high temperature and pressure	700-1202-041 remote 700-1202-042 integral	69 bar @ 121°C (1000 PSI @ 250°F) 20.7 bar @ 232°C (300 PSI @ 450°F)	316SS and PEEK
10	Corrosive liquids (2)(4)(9)	700-0001-018	3.4 bar @ 149°C (50 PSI @ 300°F)	PFA
11	General purpose, higher pressure TFE compatibility required	700-0201-005	69 bar @ 38°C (1000 PSI @ 100°F) 13.8 bar @ 232°C (200 PSI @ 450°F)	316SS and TFE
12	Corrosive material, higher pressure	700-0201-005 Hastelloy C	69 bar @ 38°C (1000 PSI @ 100°F) 13.8 bar @ 232°C (200 PSI @ 450°F)	Hastelloy C and TFE
13	Sanitary (3)	700-0201-036	69 bar @ 38°C (1000 PSI @ 100°F) 13.8 bar @ 232°C (200 PSI @ 450°F)	316/316L SS and TFE
14	General Purpose, low pressure	700-0202-002	3.4 bar @ 149°C (50 PSI @ 300°F) 1.4 bar @ 232°C (20 PSI @ 450°F)	316SS and TFE
15	Heavy duty, agitated tanks or material with high bulk density (1)	700-0202-043	69 bar @ 38°C (1000 PSI @ 100°F) 13.8 bar @ 232°C (200 PSI @ 450°F)	316SS and TFE
16	High integrity seal for hazardous material (8)	700-0002-360 (Seal Tyte™)	34.5 bar @ 149°C (500 PSI @ 300°F)	PFA (flange mounting only)
18	Corrosive material, higher pressure with waterlike viscosity (4)	700-0001-022	69 bar @ 38°C (1000 PSI @ 100°F) 34.5 bar @ 149°C (500 PSI @ 300°F)	TFE
20	Miniature Pilot Plant Sensor (1)(7)	700-0209-002	6.9 bar @ 121°C (100 PSI @ 250°F) 0 bar @ 232°C (0 PSI @ 450°F)	316 SS and TFE
60	Highest pressure and temperature (1)	700-0204-038	138 bar @ 93°C (2000 PSI @ 200°F) 69 bar @ 260°C (1000 PSI @ 500°F)	316SS and Ceramic
R	N	L		1

Model Numbering (cont.)

Sensing Element continued from previous page

Fly Ash Precipitators, Baghouse, and Economizers (1) (6)

Application	Sensing Element	Pressure/Temperature	Wetted Parts
31 No hopper installation	700-0029-001	0.1 bar @ 260°C (2 PSI @ 500°F)	316SS and TFE (CS Inactive)
32 Hopper installation up to 200mm (8 inches)	700-0029-002	0.1 bar @ 260°C (2 PSI @ 500°F)	316SS and TFE (CS Inactive)
33 Hopper installation up to 250mm (10 inches)	700-0029-003	0.1 bar @ 260°C (2 PSI @ 500°F)	316SS and TFE (CS Inactive)
35 Hopper installation up to 400mm (16 inches)	700-0029-005	0.1 bar @ 260°C (2 PSI @ 500°F)	316SS and TFE (CS Inactive)

Plugged Chute Detection (1) (5)

Application	Sensing Element	Pressure/Temperature	Wetted Parts
50 Flush Mount Sensor 305mm ² (12 inches ²) heavy duty	700-0207-001	0.1 bar @ 82°C (1 PSI @ 180°F)	304 SS and Polyurethane
51 Flush Mount Sensor 305mm ² (12 inches ²) higher temperature	700-0207-002	0.1 bar @ 149°C (1 PSI @ 300°F)	304 SS and TFE
52 Flush Mount Sensor 305mm ² (12 inches ²) with curved radius 153, 229, 305 mm (6, 9, or 12 inches)	700-0207-003	0.1 bar @ 82°C (1 PSI @ 180°F)	304 SS and Neoprene
53 Flush Mount Sensor 305mm ² (12 inches ²) extra heavy duty	700-0207-004	0.1 bar @ 82°C (1 PSI @ 180°F)	410 SS and UHMW Polyethylene
55 Flush Mount Sensor 203mm ² (8 inches ²) heavy duty	700-0207-006	0.1 bar @ 82°C (1 PSI @ 180°F)	304 SS and Polyurethane

Mounting Type (See separate Mounting Chart for first three digits)

	IL	CSL		IL	CSL
xxxA	152 mm (6")	51 mm (2")	xxxH	914 mm (36")	254 mm (10")
xxxB	305 mm (12")	51 mm (2")	xxxJ	914 mm (36")	0 mm (0")
xxxC	305 mm (12")	89 mm (3.5")	xxxK	1219 mm (48")	254 mm (10")
xxxD	457 mm (18")	51 mm (2")	xxxL	1524 mm (60")	254 mm (10")
xxxE	457 mm (18")	89 mm (3.5")	P00X	IL/CSL factory set for Plugged Chute	
xxxF	457 mm (18")	254 mm (10")	A1BX	IL/CSL factory set for Fly Ash	
xxxG	457 mm (18")	0 mm (0")	xxxZ	Other	

R	N	L				1		
---	---	---	--	--	--	---	--	--

- Notes: (1) Available with remote electronics only
 (2) Use A1P mounting option
 (3) Choose from sanitary mounting options only
 (4) Available with 0-inch CSL only
 (5) Use P00X mounting option
 (6) Use A1B mounting option
 (7) Use A8B mounting option (¼-inch NPT)
 (8) Choose from flange mounting only
 (9) FM approved with remote electronics only
Not all mounting options available with all sensing elements

NPT Threads			DIN Flanges (cont.)			ANSI Flanges (cont.)			
A1B	¾" NPT	316SS	E02	25 mm 16 bar	RF Carbon Steel	DJ1	3"	300#	RF 316/316L SS
A1C	¾" NPT	Hastelloy C	EP2	25 mm 40 bar	RF Carbon Steel	DK1	4"	150#	RF 316/316L SS
A1P	¾" NPT	PFA	EQ2	50 mm 16 bar	RF Carbon Steel	DL1	4"	300#	RF 316/316L SS
A2B	1" NPT	316SS	ER2	50 mm 40 bar	RF Carbon Steel	DM1	6"	150#	RF 316/316L SS
A2C	1" NPT	Hastelloy C	ES2	80 mm 16 bar	RF Carbon Steel	DN1	6"	300#	RF 316/316L SS
Sanitary TriClamps			ET2	80 mm 40 bar	RF Carbon Steel	DA2	1"	150#	RF Carbon Steel
C2B	1" TriClamp	316SS	EU2	100 mm 16 bar	RF Carbon Steel	DB2	1½"	150#	RF Carbon Steel
C3B	1½" TriClamp	316SS	EV2	100 mm 40 bar	RF Carbon Steel	DC2	2"	150#	RF Carbon Steel
C4B	2" TriClamp	316SS	EW2	150 mm 16 bar	RF Carbon Steel	DD2	2½"	150#	RF Carbon Steel
DIN Flanges			EX2	150 mm 40 bar	RF Carbon Steel	DE2	1"	300#	RF Carbon Steel
E01	25 mm 16bar	RF 316/316L SS	ANSI Flanges			DF2	1½"	300#	RF Carbon Steel
EP1	25 mm 40 bar	RF 316/316L SS	DA1	1"	150#	DG2	2"	300#	RF Carbon Steel
EQ1	50 mm 16 bar	RF 316/316L SS	DB1	1½"	150#	DH2	2½"	300#	RF Carbon Steel
ER1	50 mm 40 bar	RF 316/316L SS	DC1	2"	150#	DI2	3"	150#	RF Carbon Steel
ES1	80 mm 16 bar	RF 316/316L SS	DD1	2½"	150#	DJ2	3"	300#	RF Carbon Steel
ET1	80 mm 40 bar	RF 316/316L SS	DE1	1"	300#	DK2	4"	150#	RF Carbon Steel
EU1	100 mm 16 bar	RF 316/316L SS	DF1	1½"	300#	DL2	4"	300#	RF Carbon Steel
EV1	100 mm 40 bar	RF 316/316L SS	DG1	2"	300#	DM2	6"	150#	RF Carbon Steel
EW1	150 mm 16 bar	RF 316/316L SS	DH1	2½"	300#	DN2	6"	300#	RF Carbon Steel
EX1	150 mm 40 bar	RF 316/316L SS	DI1	3"	150#				



An ISO 9001 Certified Company

ABLE Instruments & Controls Limited
 Cutbush Park, Danehill, Lower Earley, Reading,
 Berkshire. RG6 4UT. United Kingdom. <http://www.able.co.uk>
 Tel: 0118 9311188 Fax: 0118 9312161 Email: info@able.co.uk