



- 1-channel
- Input EEx ia IIC
- 24 V DC nominal supply voltage
- Transfer of AC signals possible
- 2-wire sensor with current supply
- 3-wire sensor with voltage supply

Transmission range 0 V ... -20 V
KFD2-VR4-Ex1.26

Function

The device KFD2-VR4-Ex1.26 has a transfer range of 0 V ... 20 V. In the hazardous area the terminals 5 and 6 (2) have a negative polarity in respect to terminal 4. The sensor power supply (terminal 5) is resistively limited, sensors which require a current supply can be connected to the terminals 3 or 1 alternatively. The DC signal at terminals 6 and 4 can be superimposed by a AC signal (sinus 0 kHz ... 20 kHz; 20 Vp-p.) .

Application

The transfer of signals from oscillation sensors from Bently (Nevada) and other providers

Connection

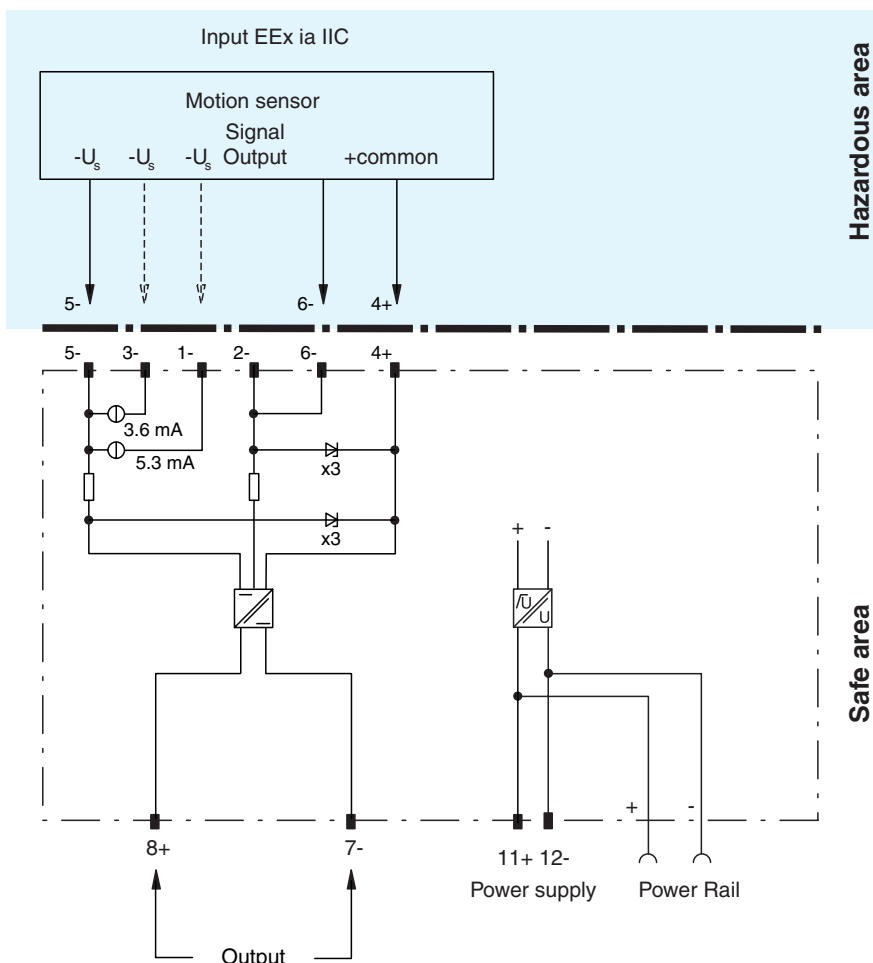

Composition

Front View

Housing type A2
 (see system description)

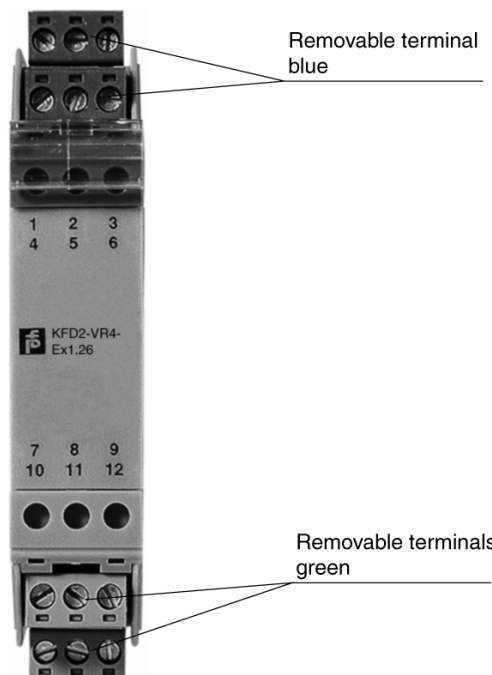

Supply	
Connection	Power Rail or terminals 11+, 12-
Rated voltage	20 ... 35 V DC
Ripple	within the supply tolerance
Power consumption	< 1,6 W
Input	
Connection	terminals 4+, 5-, 2- and 6-; 1+, 3+, 5-
Input resistance	10 kΩ terminals 4+, 6- / 2-
Output rated operating current	terminals 4+, 5-: > 10 mA at -21 V or > 20 mA at -18 V terminals 4+, 1-: > 5.3 mA ±0.1 mA at -10 V terminals 4+, 3-: > 3.6 mA ±0.7 mA at -10 V
Transmission range	0 ... -20 V
Output	
Connection	terminals 7-, 8+
Voltage	0 ... -20 V
Output resistance	approx. 10 Ω
Transfer characteristics	
Deviation	
After calibration	±5 mV at 293 K (20 °C) including non-linearity at any point within the span, provided that the alternating component of the input voltage is not excessive, e. g. square waves (0 ... 20 kHz) = 5 V peak to peak sine waves (0 ... 20 kHz) the full span of 20 V peak to peak (= 100 g peak acceleration at 100 mV/g) is acceptable
Temperature	(< 50 ppm of span)/K at any point within the span
Bandwidth	-0.1 dB at 10 kHz; -1 dB at 20 kHz
Electrical isolation	
Input/Output	safe electrical isolation acc. to EN 50020, voltage peak value 375 V
Input/power supply	safe electrical isolation acc. to EN 50020, voltage peak value 375 V
Output/power supply	basic insulation acc. to DIN EN 50178, rated insulation voltage of AC 50 V
Directive conformity	
Electromagnetic compatibility	
Directive 89/336/EC	on request
Standard conformity	
Climatic conditions	acc. to DIN IEC 721
Ambient conditions	
Ambient temperature	-20 ... 60 °C (253 ... 333 K)
Mechanical specifications	
Protection degree	IP20
Mass	approx. 100 g
Data for application in conjunction with hazardous areas	
EC-Type Examination Certificate	BAS 02 ATEX 7206 ; for additional certificates see www.pepperl-fuchs.com
Group, category, type of protection	Ⓧ II (1) G D [Ex ia] IIC
Supply	
Voltage U ₀	25,2 V
Current I ₀	90 mA
Power P ₀	570 mW
Signal	
terminals	5-, 3+, 1+ / 4+; 6-, 2- and 4+
Voltage U ₀	≤ 1,2 V
Current I ₀	≤ 0,12 mA
Power P ₀	≤ 0,036 mW
Type of protection [Ex ia]	
Supply	
terminals	4+ and 5-; 3- and 1+
Explosion group	IIA IIB IIC
External capacitance	2,48 μF 0,74 μF 96 nF
External inductance	24,4 mH 9,15 mH 3,05 mH
Signal	
terminals	5-, 3+, 1+ / 4+
Explosion group	IIA IIB IIC
External capacitance	1000 μF 1000 μF 100 μF
External inductance	1000 mH 1000 mH 1000 mH
Electrical isolation	
Input/Output	safe electrical isolation acc. to EN 50020, voltage peak value 375 V
Input/power supply	safe electrical isolation acc. to EN 50020, voltage peak value 375 V
Directive conformity	
Directive 94/9 EC	on request

117144_ENG.xml

09/09/04

Notes

Connection

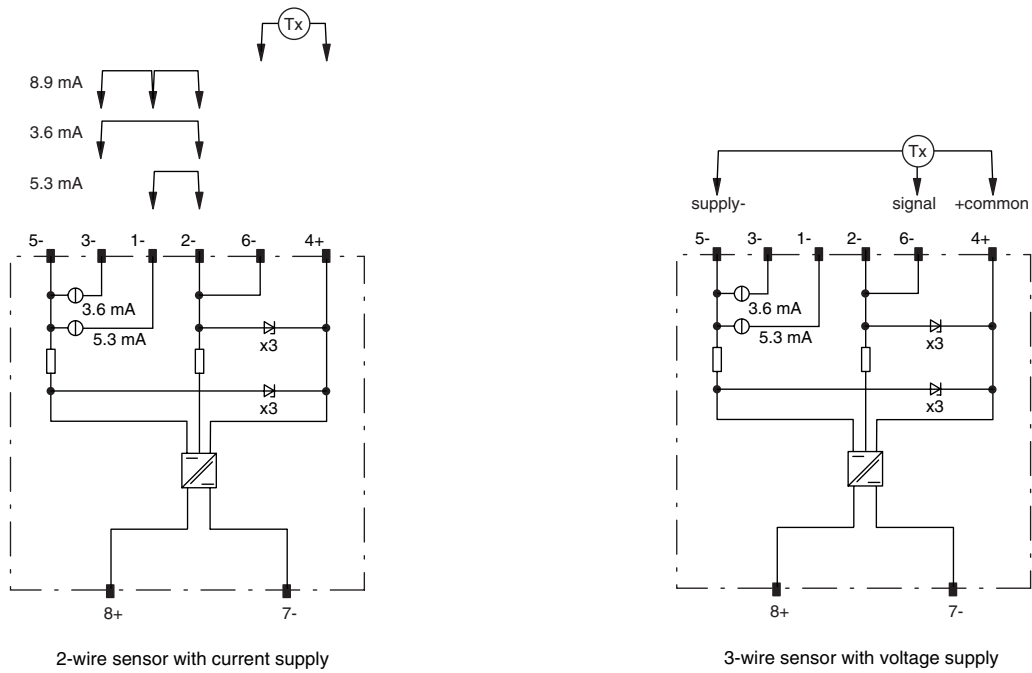

Installation

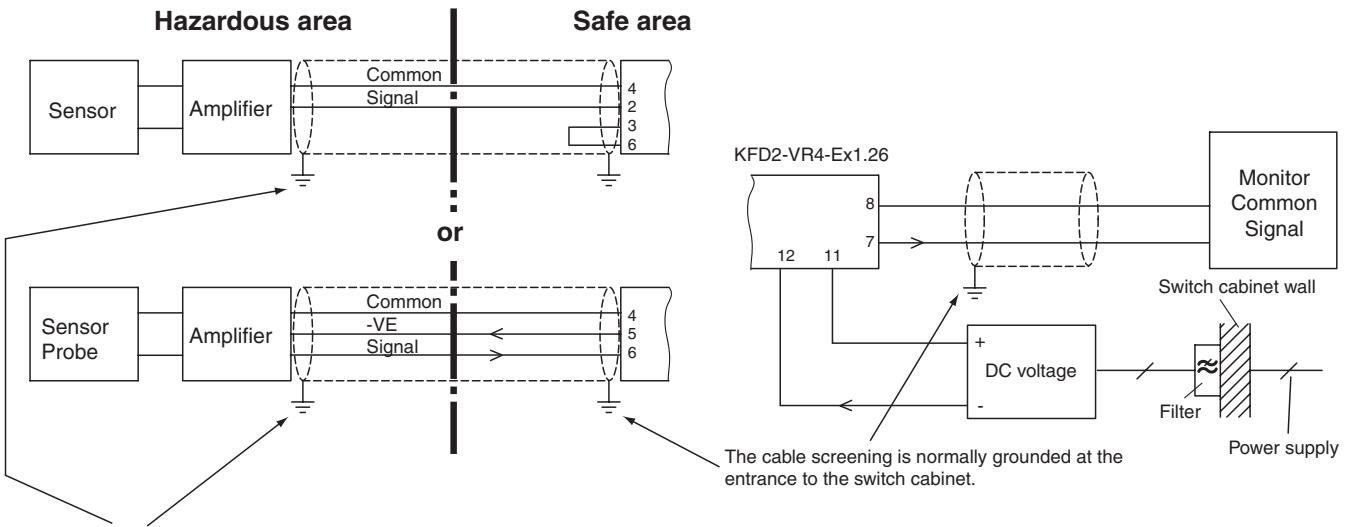

If the motion sensor (sensor and amplifier) is not grounded, the cable screening must not be grounded at this end. It may, however, be safely insulated. If the amplifier is grounded then the cable screening should also be grounded. In general, the manufacturers guidelines should be adhered to.

The cable screening may be grounded with the standard rail, upon which the interface modules are mounted, when the cabinet doors are left open with a transmitter being operated nearby. The resistance to radio frequency interference of other units in the switching cabinet may be influenced hereby.

Accessories

- PR-03 Power Rail
- UPR-03 Power Rail
- KFD2-EB2 power feed module

The KFD2-EB2 power feed module and the PR-03 or the UPR-03 Power Rail are used to supply the devices with 24 VDC and at the same time to evaluate collective error message.

Each power feed module monitors and provides protection for up to 100 individual devices. The PR-03 Power Rail is an insert component for the DIN rail. The UPR-03 Power Rail is a complete unit consisting of an electrical insert and an aluminium DIN rail measuring 35 mm x 15 mm x 2000 mm. The devices are simply snapped in place to make electrical contact.

If a Power Rail is not being used, power can be supplied to the devices directly through the device terminals.

117144_ENG.xml

09/09/04