



Input 4 mA ... 20 mA
Output 4 mA ... 20 mA

- 2-channel
- Input EEx ia IIC; $U_0 = 25.2 V$
- Device installation permissible in zone 2
- 24 V DC nominal supply voltage
- SMART capable up to 7.5 kHz (-3 dB)
- EMC acc. to NAMUR NE 21
- Usable up to SIL 2 acc. to IEC 61508

Function

SMART transmitter power supplies provide 2-wire SMART transmitters with power in hazardous areas and transfer the analogue value of 4 mA ... 20 mA from the hazardous to the safe area. Digital signals may be superimposed on the analogue values in the hazardous or safe area, which may be transferred bidirectionally. Handheld terminals should be connected as shown in the block diagramm.

In case of a too low loop resistance, an internal resistance of approx. 274 Ohm between terminals 8 (11) and 9 (12) is available, which can be used as HART resistor.

SMART transmitter power supplies are delivered standard with terminals KF-STP-BU and KF-STP-GN. Jacks are integrated in these terminals for the connection of the handheld units.

Application

- Power supply for SMART transmitters and transfer of the measurement current to the output
- suited for the following SMART systems:

ABB	Foxboro
Endress+Hauser	Fuji
Emerson	Smarr
Yokogawa	

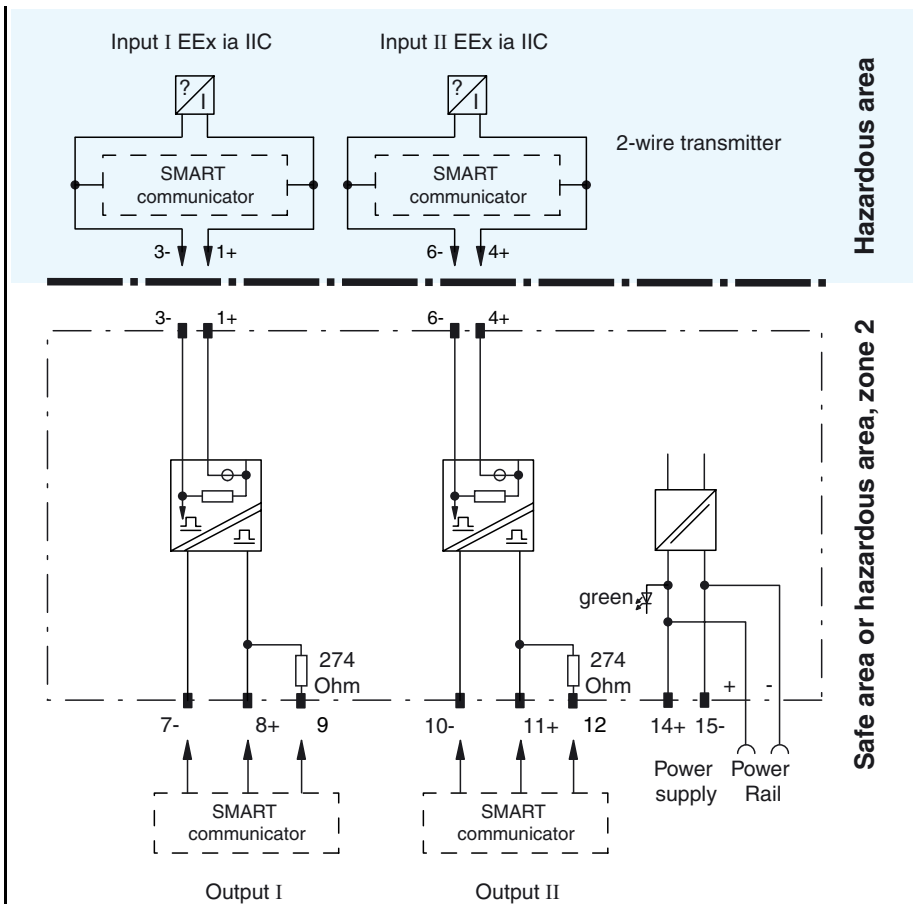

Composition

Front View

Housing type C
 (see system description)

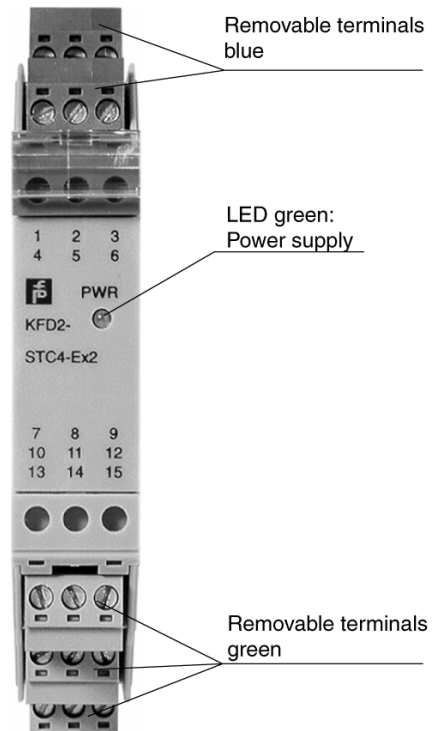

Supply	
Connection	Power Rail or terminals 14+, 15-
Rated voltage	20 ... 35 V DC
Ripple	within the supply tolerance
Power loss	1,9 W
Power consumption	≤ 2,8 W
Input	
Connection	terminals 1+, 3-; 4+, 6-
Input signal	4 ... 20 mA
Input resistance	≤ 64 Ω terminals 2-, 3
Available voltage	≥ 16 V at 20 mA, terminals 1+, 3
Output	
Connection	terminals 7-, 8+; 10-, 11+
Output signal	4 ... 20 mA ; load: 0 ... 550 Ω
Ripple	≤ 50 μA _{rms}
Transfer characteristics	
Deviation	± 0.1 % incl. calibration, linearity, hysteresis, load and nominal mains voltage fluctuations at 293 K (20 °C)
Temperature	0.4 μA/°C
Frequency range	hazardous area into the safe area: bandwidth with 1 V _{SS} -signal 0 ... 7,5 kHz (-3 dB) safe area to hazardous area: bandwidth with 1 V _{SS} -signal 0,3 ... 7,5 kHz (-3 dB)
Rise time	20 μs
De-energised delay	20 μs
Electrical isolation	
Output/Power supply	basic insulation acc. to DIN EN 50178, rated insulation voltage of AC 50 V
Output/Output	basic insulation acc. to DIN EN 50178, rated insulation voltage of AC 50 V
Directive conformity	
Electromagnetic compatibility	standards
Directive 89/336/EEC	EN 61326, EN 50081-2, NE 21
Standard conformity	
Electromagnetic compatibility	acc. to EN 50081-2 / EN 50082-2, NAMUR NE 21
Climatic conditions	acc. to DIN IEC 721
Ambient conditions	
Ambient temperature	-20 ... 60 °C (253 ... 333 K)
Mechanical specifications	
Protection degree	IP20
Mass	approx. 150 g
Data for application in conjunction with hazardous areas	
EC-Type Examination Certificate	BAS 99 ATEX 7025 , for additional certificates see www.pepperl-fuchs.com
Group, category, type of protection	⊕ II (1) G [EEx ia] IIC (-20 °C ≤ T _{amb} ≤ 60 °C) [circuit(s) in zone 0/1/2]
Input	EEx ia IIC
Voltage U ₀	25,2 V
Current I ₀	93 mA
Power P ₀	0,586 W
Supply	
Safety maximum voltage U _m	250 V (Attention! The rated voltage can be lower)
Type of protection [EEx ia]	
Explosion group	IIA IIB IIC
External capacitance	2,888 μF 0,808 μF 0,095 μF
External inductance	33 mH 17 mH 4,2 mH
Statement of conformity	
Group, category, type of protection, Temperature classification	⊕ II 3 G EEx nA II T4 [device in zone 2]
Electrical isolation	
Input/Output	safe electrical isolation acc. to EN 50020, voltage peak value 375 V
Input/Power supply	safe electrical isolation acc. to EN 50020, voltage peak value 375 V
Directive conformity	
Directive 94/9 EC	EN 50014, EN 50020, EN 50021

Supplementary information

EC-Type Examination Certificate, Statement of Conformity, Declaration of Conformity and instructions have to be observed. For information see www.pepperl-fuchs.com.

Accessories

PR-03 Power Rail

UPR-03 Power Rail

KFD2-EB2 power feed module

The devices are supplied with 24 V DC through the KFD2-EB2 power feed module and the PR-03 or the UPR-03 Power Rail. Each power feed module monitors and provides protection for groups of as many as 100 individual devices. The PR-03 Power Rail is an insert component for the DIN rail. The UPR-03 Power Rail is a complete unit consisting of an electrical insert and an aluminium DIN rail measuring 35 mm x 15 mm x 2000 mm. The devices are simply snapped in place to make electrical contact.

If a Power Rail is not being used, power can be supplied to the devices directly through the device terminals.