



24 V DC

- 2-channel
- Control circuit EEx ia IIC
- Device installation permissible in zone 2
- Reversible mode of operation
- 1 active electronic output per channel
- EMC acc. to NAMUR NE 21
- LB/SC monitoring
- LB/SC collective error message via Power Rail
- Usable up to SIL 2 acc. to IEC 61508

Function

The transformer isolated barrier transfers digital signals from the hazardous area. Sensors per DIN EN 60947-5-6 (NAMUR) and mechanical contacts may be used as alarms. The control circuit monitored for lead breakage (LB) and short circuit (SC). The external faults are indicated according to NAMUR NE44 by a red flashing LED. Additionally a LB/SC collective error message will be transferred via Power Rail to the power feed module. The intrinsically safe inputs per DIN EN 50020 are safely isolated from the output and the power supply. Both transistor outputs are galvanically connected to each other and the power supply.

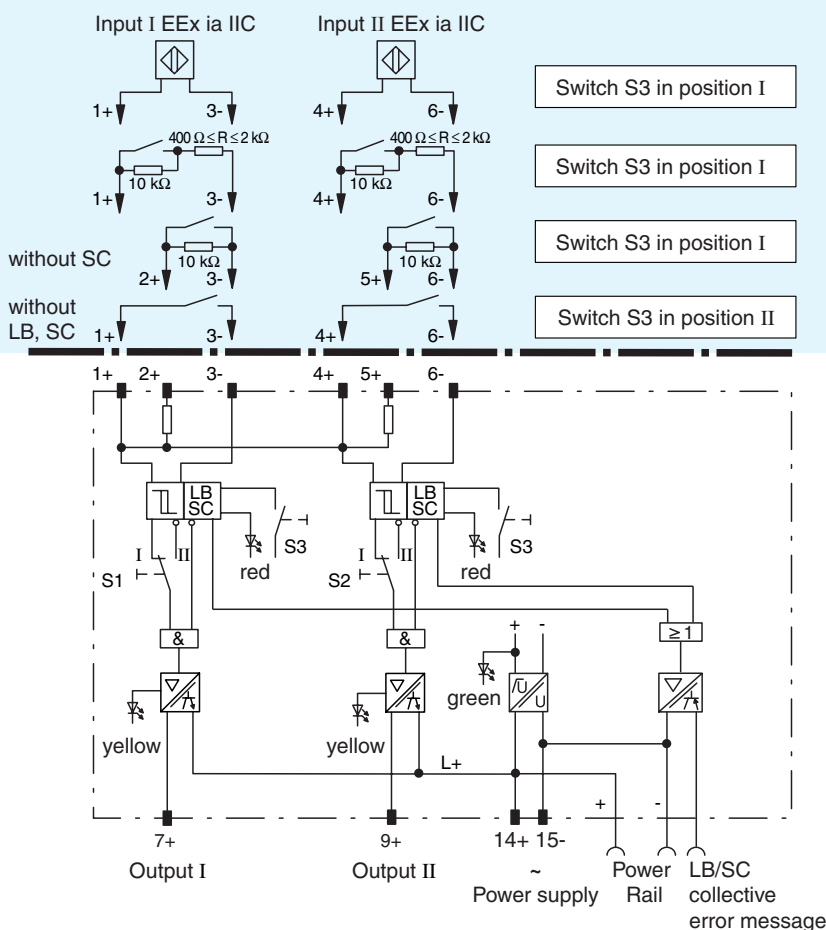

Hazardous area

Safe area or hazardous area, zone 2

Composition

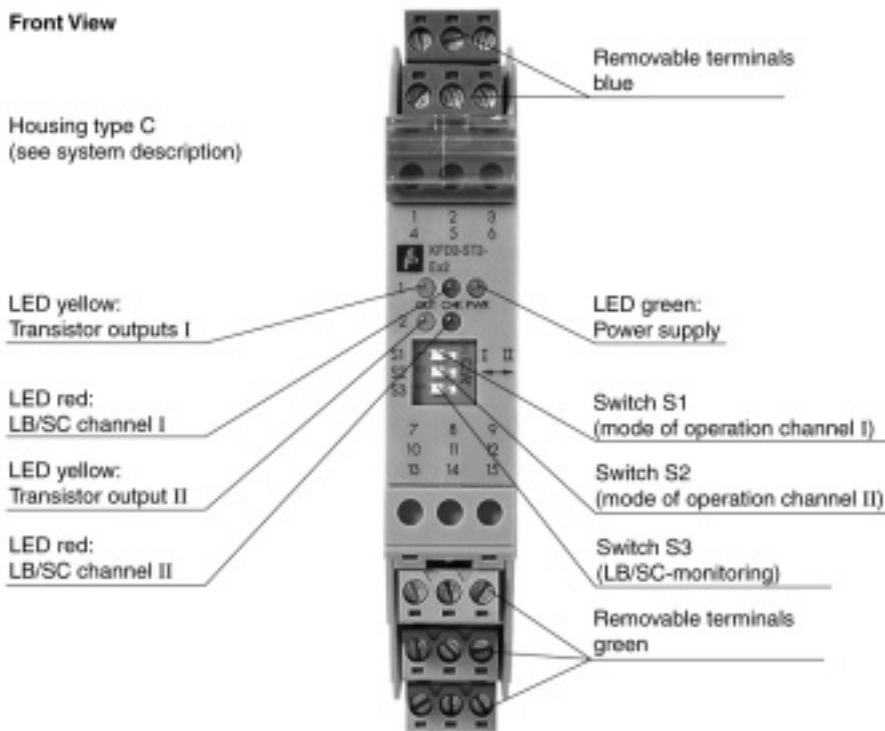

Supply	
Connection	Power Rail or terminals 14+, 15-
Rated voltage	20 ... 30 V DC
Ripple	≤ 10 %
Rated current	≤ 50 mA
Input	
Connection	terminals 1+, 2+, 3-; 4+, 5+, 6-
Rated values	acc. to IEC 60947-5-6 (NAMUR, DIN 19234), see system description for electrical data
Open circuit voltage/Short-circuit current	approx. 8 V DC / approx. 8 mA
Switching point/Switching hysteresis	1,2 ... 2,1 mA / approx. 0,2 mA
Lead monitoring	breakage I ≤ 0,1 mA , short-circuit I > 6 mA
Output	
Connection	output I: terminals 7+ ; output II: terminals 9+
Collective error message	Power Rail
Signal level	1-signal: (L+) - 3.5 V (100 mA, short-circuit proof) 0-signal: switched off (off-state current ≤ 10 μA)
Output I	signal ; electronic output, active
Output II	lead breakage ; electronic output, active
Transfer characteristics	
Switching frequency	≤ 5 kHz
Electrical isolation	
Output/Power supply	not available , common pole terminal 14+
Output/Output	not available , common pole terminal 14+
Standard conformity	
Climatic conditions	acc. to DIN IEC 721
Directive conformity	
Electromagnetic compatibility	standards
Directive 89/336/EG	EN 61326, EN 50081-2, NE 21
Ambient conditions	
Ambient temperature	-20 ... 60 °C (253 ... 333 K)
Mechanical specifications	
Protection degree	IP20
Mass	approx. 150 g
Data for application in conjunction with hazardous areas	
EC-Type Examination Certificate	PTB 00 ATEX 2035 , for additional certificates see www.pepperl-fuchs.com
Group, category, type of protection	⊕ II (1) G D [Ex ia] IIC [circuit(s) in zone 0/1/2]
Input	EEx ia IIC
Voltage U ₀	10,5 V
Current I ₀	13 mA
Power P ₀	34 mW (linear characteristic)
Type of protection [EEx ia and EEx ib]	
Explosion group	IIA IIB IIC
External capacitance	75 μF 16,8 μF 2,4 μF
External inductance	1000 μH 740 μH 200 μH
Statement of conformity	TÜV 99 ATEX 1499 X , observe statement of conformity
Group, category, type of protection, Temperature classification	⊕ II 3 G EEx nA II T4 [device in zone 2]
Supply	
Safety maximum voltage U _m	40 V DC (Attention! The rated voltage can be lower)
Output	
Safety maximum voltage U _m	40 V DC (Attention! The rated voltage can be lower)
Electrical isolation	
Input/Input	not available
Input/Output	safe electrical isolation acc. to EN 50020, voltage peak value 375 V
Input/Power supply	safe electrical isolation acc. to EN 50020, voltage peak value 375 V
Directive conformity	
Directive 94/9 EU	EN 50014, EN 50020, EN 50021
Entity parameter	
Certification number	J.I.3002773
FM control drawing	No. 116-0035
Suitable for installation in division 2	yes
Connection	terminals 1, 3; 2, 3; 4, 6; 5, 6
Input I	
Voltage V _{OC}	12,9 V
Current I _t	19,8 mA

Explosion group	A&B	C&E	D, F&G
Max. external capacitance C_a	1,273 μ F	3,82 μ F	10,18 μ F
Max. external inductance L_a	84,8 mH	254,4 mH	678,4 mH
Safety parameter			
UL control drawing	E 106378		
CSA control drawing	LR 36087-19/LR 36087-22		
Control drawing	No. 116-0047		
Connection	terminals 1, 3; 2, 3; 4, 6; 5, 6		
Input I			
Voltage V_{OC}	10,5 V		
Current I_{SC}	13 mA		
Explosion group	A&B	C&E	D, F&G
Max. external capacitance C_a	2,66 μ F	7,9 μ F	21,3 μ F
Max. external inductance L_a	192 mH	671 mH	1000 mH

Notes

Lead breakage monitoring

The output is cut-off when the current in the control circuit is $J < 0,1$ mA (per lead breakage monitoring). In the case of an error, a fault signal is switched on the Power Rail (UPR-03). The power feed module evaluates and passes on the fault signal by means of a potentially free contact.

Supplementary information

EC-Type Examination Certificate, Statement of Conformity, Declaration of Conformity and instructions have to be observed. This information can be found under www.pepperl-fuchs.com

Accessories

PR-03 Power Rail

UPR-03 Power Rail

KFD2-EB2 power feed module

The KFD2-EB2 power feed module and the PR-03 or the UPR-03 Power Rail are used to supply the devices with 24 VDC and at the same time to evaluate combined fault indications.

Each power feed module monitors and provides protection for groups of as many as 100 individual devices. The PR-03 Power Rail is an insert component for the DIN rail. The UPR-03 Power Rail is a complete unit consisting of an electrical insert and an aluminium DIN rail measuring 35 mm x 15 mm x 2000 mm. The devices are simply snapped in place to make electrical contact.

If a Power Rail is not being used, power can be supplied to the devices directly through the device terminals.