



- 1-channel
- Input EEx ia IIC
- Device installation permissible in zone 2
- 24 V DC nominal supply voltage
- Accuracy 0.1 %
- EMC acc. to NAMUR NE 21

**Function**

The KFD2-RR-Ex1 transfers the resistance value ( $R_m$ ) of a temperature sensor (e.g. Pt100, Pt500, Pt1000, ...) in the 2-, 3- or 4- wire mode. The connection of a converter located in the safe area in the 2-, 3- or 4- wire mode may also be successfully employed. The converter determines the measurement current ( $I_m$ ). The current is transferred to the hazardous area by the repeater and causes a voltage drop at the temperature sensor. This voltage is then reproduced in the safe area by the repeater. The present resistance value of the sensor is thereby reproduced at the repeater output. All resistance repeaters are compatible provided measurement current  $\times (R_m + 900 \Omega) < 10 \text{ V}$  and measurement voltage  $< 7 \text{ V}$ .

**Application**

As an Ex-isolator between the temperature sensor in the hazardous area and the converter or thermometer in the safe area.

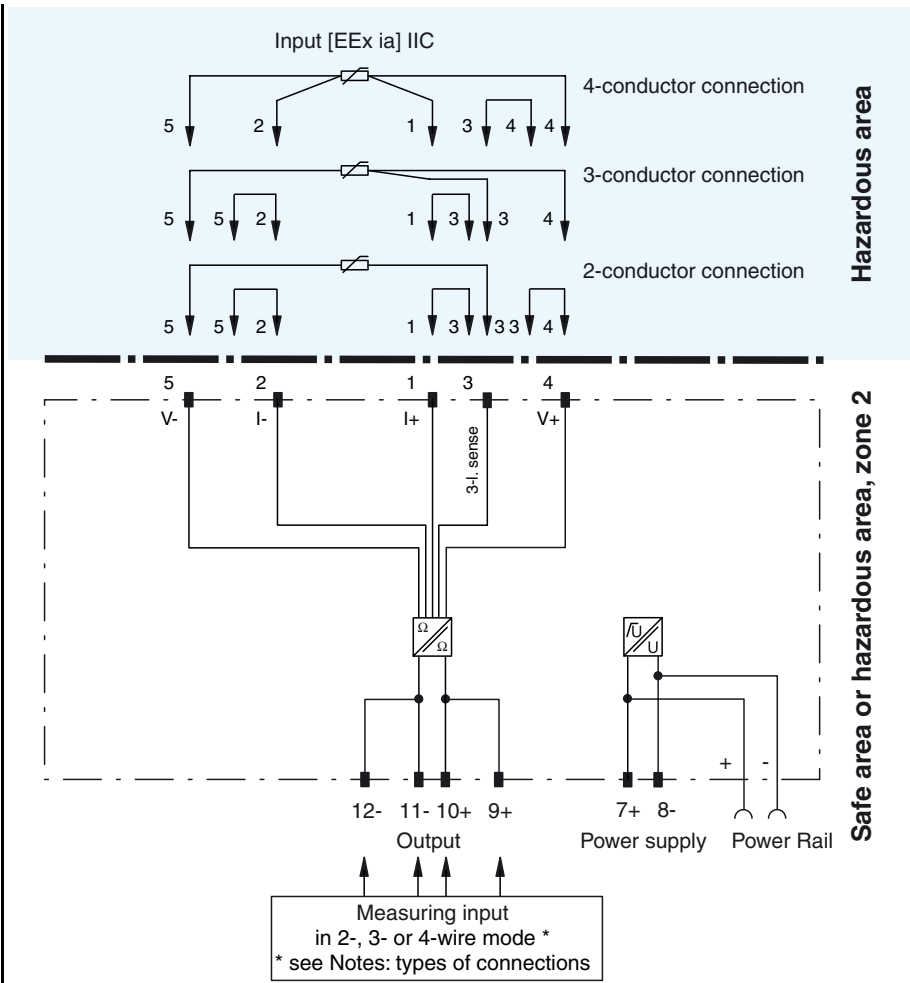

**Composition**

Front View

Housing type A4 (see system description)

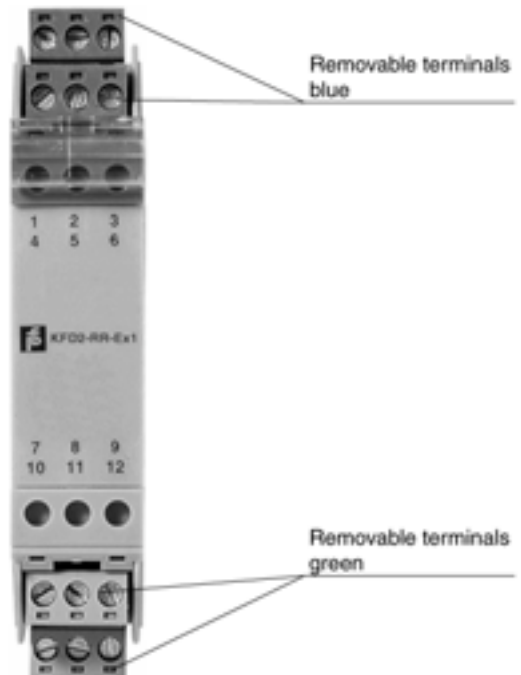

|   |  |                                      |
|---|--|--------------------------------------|
| <b>Supply</b>   |  |                                      |
| Connection  | Power Rail or terminals 7+, 8-   |                                      |
| Rated voltage   | 20 ... 35 V DC   |                                      |
| Ripple  | within the supply tolerance  |                                      |
| Rated current   | < 20 mA  |                                      |
| Power loss  | 0.25 W (24 V and 1 mA sense current)   |                                      |
| <b>Input</b>  |  |                                      |
| Connection  | terminals 1, 2, 3, 4, 5  |                                      |
| Lead resistance   | ≤ 10 % of resistance value   |                                      |
| Transmission range  | 0 ... 10 mA  |                                      |
| Available voltage   | 9 V  |                                      |
| <b>Output</b>   |  |                                      |
| Connection  | terminals 12-, 11-, 10+, 9+  |                                      |
| Current   | 0 ... 10 mA  |                                      |
| Available voltage   | 0 ... 7 V  |                                      |
| Safety maximum voltage $U_m$                                    | 250 V  |                                      |
| <b>Transfer characteristics</b>                                 |  |                                      |
| Deviation   | $I_m \geq 1 \text{ mA}$ : $\pm 0.1 \%$ of $R_m$ or $\pm 0.1 \Omega$ (the larger value is applicable)<br>$I_m < 1 \text{ mA}$ : Accuracy reduces in proportion to $I_m$ .<br>e.g. $I_m = 0.1 \text{ mA}$ : $\pm 1 \%$ of $R_m$ or $1 \Omega$ (the larger value is applicable).  |                                      |
| Temperature   | $I_m \geq 1 \text{ mA}$ , $R_m \geq 100 \Omega$ : $0.01 \%$ / K in the range $-20 \dots +60 \text{ }^\circ\text{C}$ (253 ... 333 K)<br>$I_m < 1 \text{ mA}$ or $R_m < 100 \Omega$ : temperature stability reduces in proportion to $I_m$ or $R_m$  |                                      |
| Rise time   | Signal response time $\leq 2 \text{ ms}$ (10 ... 90 %)<br>Response to application of $I_m$ : $R_m > 50 \Omega$ and $I_m < 5 \text{ mA}$ : $< 5 \text{ ms}$<br>Response to application of $I_m$ : $R_m > 30 \Omega$ and $I_m < 5 \text{ mA}$ : $< 10 \text{ ms}$<br>Response to application of $I_m$ : $R_m > 18 \Omega$ and $I_m < 5 \text{ mA}$ : $< 20 \text{ ms}$ |                                      |
| <b>Electrical isolation</b>                                     |  |                                      |
| Input/Output  | safe electrical isolation acc. to EN 50020, voltage peak value 375 V   |                                      |
| Input/Power supply  | safe electrical isolation acc. to EN 50020, voltage peak value 375 V   |                                      |
| Output/Power supply   | basic insulation acc. to DIN EN 50178, rated insulation voltage of AC 50 V   |                                      |
| <b>Directive conformity</b>                                     |  |                                      |
| Electromagnetic compatibility                                   | standards  |                                      |
| Directive 89/336/EC   | on request   |                                      |
| <b>Standard conformity</b>                                      |  |                                      |
| Coordination of insulation                                      | acc. to DIN EN 50178   |                                      |
| Electrical isolation  | acc. to DIN EN 50178   |                                      |
| Electromagnetic compatibility                                   | acc. to EN 50081-2 / EN 50082-2, NAMUR NE 21, DIN IEC 801-2 and DIN IEC 801-4 ... 6  |                                      |
| Climatic conditions   | acc. to DIN IEC 721  |                                      |
| <b>Ambient conditions</b>                                       |  |                                      |
| Ambient temperature   | $-20 \dots 60 \text{ }^\circ\text{C}$ (253 ... 333 K)  |                                      |
| <b>Mechanical specifications</b>                                |  |                                      |
| Protection degree   | IP20   |                                      |
| Mass  | approx. 100 g  |                                      |
| <b>Data for application in conjunction with hazardous areas</b> |  |                                      |
| EC-Type Examination Certificate                                 | BAS 01 ATEX 7282 ; for additional certificates see <a href="http://www.pepperl-fuchs.com">www.pepperl-fuchs.com</a>  |                                      |
| Group, category, type of protection                             | $\text{Ex}$ II (1) G D [EEx ia] IIC ( $-20 \text{ }^\circ\text{C} \leq T_a \leq 60 \text{ }^\circ\text{C}$ )   |                                      |
| Voltage $U_0$   | 12,4 V   |                                      |
| Current $I_0$   | 17 mA  |                                      |
| Power $P_0$   | 53 mW  |                                      |
| <b>Supply</b>   |  |                                      |
| Safety maximum voltage $U_m$                                    | 250 V  |                                      |
| <b>Type of protection [EEx ia]</b>                              |  |                                      |
| Explosion group   | IIA  | IIB IIC                              |
| External capacitance  | 30 $\mu\text{F}$   | 7,9 $\mu\text{F}$ 1,24 $\mu\text{F}$ |
| External inductance   | 855 mH   | 458 mH 120 mH                        |
| Statement of conformity   | TÜV 99 ATEX 1499 X (observe statement of conformity)   |                                      |
| Group, category, type of protection, Temperature classification | $\text{Ex}$ II 3 G EEx nA II T4  |                                      |
| <b>Electrical isolation</b>                                     |  |                                      |
| Input/Output  | safe electrical isolation acc. to EN 50020, voltage peak value 375 V   |                                      |
| <b>Directive conformity</b>                                     |  |                                      |
| Directive 94/9 EC   | on request   |                                      |
| <b>Entity parameter</b>   |  |                                      |
| Certification number  | 4Z6A5.AX   |                                      |
| FM control drawing  | No. 116-0129   |                                      |
| Suitable for installation in division 2                         | yes  |                                      |

127819\_ENG.xml 2004-01-27

|                                 |                         |              |               |
|---------------------------------|-------------------------|--------------|---------------|
| Connection                      | terminals 1, 2, 3, 4, 5 |              |               |
| Input I                         |                         |              |               |
| Current                         | $I_t$                   | 17,4 mA      |               |
| Voltage                         | $V_t$                   | 12,8 V       |               |
| Explosion group                 | A&B                     | C&E          | D, F&G        |
| Max. external capacitance $C_a$ | 1,33 $\mu$ F            | 3,99 $\mu$ F | 10,64 $\mu$ F |
| Max. external inductance $L_a$  | 108,6 mH                | 381,1 mH     | 957,8 mH      |
| <b>Safety parameter</b>         |                         |              |               |
| CSA control drawing             | LR 65756-13             |              |               |
| Control drawing                 | No. 116-0132            |              |               |
| Connection                      | terminals 1, 2, 3, 4, 5 |              |               |
| Input I                         |                         |              |               |
| Voltage                         | $V_{OC}$                | 11,6 V       |               |
| Current                         | $I_{SC}$                | 15,6 mA      |               |
| Explosion group                 | A&B                     | C&E          | D, F&G        |
| Max. external capacitance $C_a$ | 1,8 $\mu$ F             | 5,6 $\mu$ F  | 15 $\mu$ F    |
| Max. external inductance $L_a$  | 1000 mH                 | 1000 mH      | 1000 mH       |

**Notes**

**Connection types:**

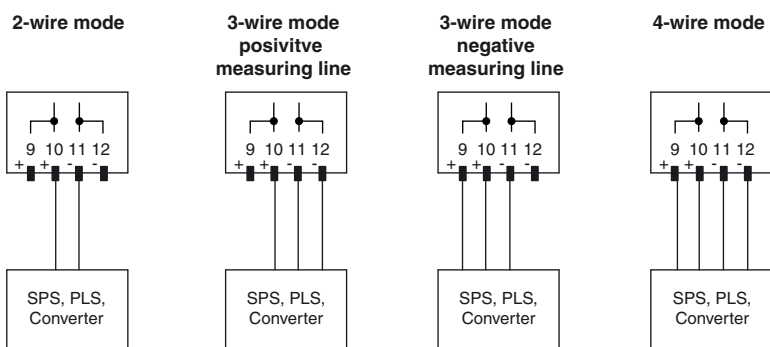

In the case of fast multiplex input cards, transmission problems might be experienced in connection with low resistance values and/or high sensor currents. For data see Rise Time

**Measurement range:**

The isolated transformer can convey a maximum of 10 mA and a maximum of 7 V. The maximum transferable resistance value can be derived from the following equation:

Resistance value = 7 V/sensing current

The sensing current is determined by the original Non-Ex converter.

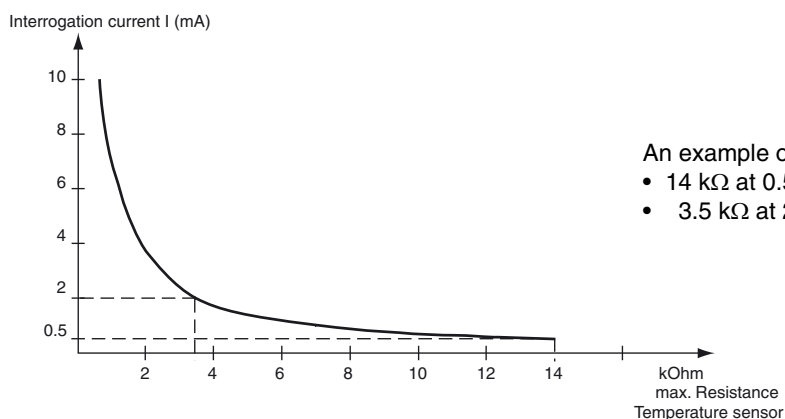

- An example of the maximum transferable resistance value:
- 14 k $\Omega$  at 0.5 mA sensing current
  - 3.5 k $\Omega$  at 2 mA sensing current

## Accessories

### **PR-03 Power Rail**

### **UPR-03 Power Rail**

### **KFD2-EB2 power feed module**

The devices are supplied with 24 V DC through the KFD2-EB2 power feed module and the PR-03 or the UPR-03 Power Rail. Each power feed module monitors and provides protection for groups of as many as 100 individual devices. The PR-03 Power Rail is an insert component for the DIN rail. The UPR-03 Power Rail is a complete unit consisting of an electrical insert and an aluminium DIN rail measuring 35 mm x 15 mm x 2000 mm. The devices are simply snapped in place to make electrical contact.

If a Power Rail is not being used, power can be supplied to the devices directly through the device terminals.